



AGENDA
FORT SCOTT CITY COMMISSION
FORT SCOTT CITY HALL
COMMISSION ROOM
123 SOUTH MAIN
FEBRUARY 20, 2018
6:00 P.M.

I. ROLL CALL:

ADAMSON BARTELSMEYER NICHOLS PARKER MITCHELL

II. FLAG SALUTE

III. INVOCATION: Pastor Ian Johnson, Youth Minister, Community Christian Church

IV. PROCLAMATIONS/RECOGNITIONS:

Recognition of Fort Scott High School Girls Wrestling Team

Introduction of new City employees

V. CONSENT AGENDA:

- A. Approval of minutes of the regular meeting of February 6th, 2018.
- B. Approval of Appropriation Ordinance 1209-A totaling \$320,132.82.
- C. Approval of Archer Daniels Midland Agreement – purchase of treated wastewater from City of Fort Scott
- D. Certificate of Appropriateness – Installation of Bicycle Racks in downtown area
- E. Certificate of Appropriateness – Approval of final Gordon Parks sign to be installed on Iron Star Building

VI. APPEARANCE/COMMENTS/PUBLIC HEARING:

A. APPEARANCE: None

B. CITIZEN COMMENTS (Concerning Items Not on Agenda – 3 minute limit per citizen) -

F. PUBLIC HEARINGS/COMMENTS: None

VII. CONSIDERATION:

1. Consideration of zoning change - A change of zoning from R-2 (Medium Density Residential District) to MU (Mixed Use District) – For Tract #1 at 1907 S. Horton – Approval of Ordinance No. 3530
2. Consideration of Zoning change - A change of zoning from R-2 (Medium Density Residential District) to R-3 (High Density Residential District) for Tract #2 at 1920 S. Huntington – Approval of Ordinance No. 3531
3. Consideration of playhouse placement
4. Consideration of Fitness Equipment purchase – Buck Run Community Center
5. Consideration of Natural Gas Supply Agreement with Constellation for Memorial Hall and the Public Works building

VIII. COMMENTS:

A. Director Updates:

B. Commission:

C. City Attorney:

D. Director of Finance:

E. City Manager:

EXECUTIVE SESSION:

I MOVE THAT THE CITY COMMISSION RECESS INTO EXECUTIVE

SESSION FOR _____ IN ORDER TO
(see below justification)

DISCUSS _____ . THE

EXECUTIVE SESSION WILL BE _____ MINUTES AND THE OPEN

MEETING TO RESUME AT _____.

Justifications for Executive Sessions:

- Personnel matters of non-elected personnel
- Consultation with an attorney for the body or agency which would be deemed privileged in the attorney-client relationship

AGENDA
FORT SCOTT CITY COMMISSION
FORT SCOTT CITY HALL
COMMISSION ROOM
123 SOUTH MAIN
FEBRUARY 20, 2018
6:00 P.M.

- Matters relating to employer-employee negotiations whether or not in consultation with the representative or representatives of the body or agency
- Confidential data relating to financial affairs or trade secrets of corporations, partnerships, trusts and individual proprietorships
- Preliminary discussions relating to the acquisition of real property

X. MOTION FOR ADJOURNMENT: *ROLL CALL*

**CITY OF FORT SCOTT
CITY COMMISSION MEETING**

Minutes of February 6, 2018

Regular Meeting #3

The regular meeting of the Fort Scott City Commission was held February 6th, 2018 at 6:00 p.m. in the City Commission Room, 123 S. Main, Fort Scott, Kansas.

ROLL CALL:

Commissioners Adamson, Bartelsmeyer, Nichols and Parker were present with Mayor Mitchell presiding.

INVOCATION: Pastor Jason Shackelford, Margrave Church of Christ, said a prayer asking God for guidance for the city and all government and city officials.

AUDIENCE IN ATTENDANCE: Travis Shelton, James Charlesworth, Venita Ballweber, Kenny Howard, Chad Brown, Jason Shackelford, Janet Braun, Shannon O'Neil, Jerry Morgan, Rachel Pruitt, Lindsay Madison, James Birket, Kevin Davidson, Clayton Miller, Darrell Parker, Frank Adamson, Paul Ballou, Rhonda Dunn, Deb Needleman, and Jason Silvers, representing the Fort Scott Tribune.

PROCLAMATIONS/RECOGNITIONS: Introduction of new City employee – Deb Needleman, Human Resource Director introduced a new Police Officer: Kevin Davidson. He started on January 29th, 2018.

APPROVAL OF MINUTES AND APPROPRIATIONS/CONSENT AGENDA:

- A. Approval of minutes of the regular meeting of January 16th, 2018
- B. Approval of Appropriation Ordinance 1208-A totaling \$639,873.81.
- C. Resolution 4-2018 – Notice of Hearing with Reference to Alleged Dangerous and Unsafe Structure and Accessory Structure located at 1523 E. Wall Street – Public Hearing Date – 3/20/2018 – 6:15 p.m.
- D. Resolution 5-2018 – Notice of Hearing with Reference to Alleged Dangerous and Unsafe Structure and Accessory Structure located at 1601 E. Wall Street – Public Hearing Date – 3/20/2018 – 6:15 p.m.
- E. Resolution 6-2018 – Notice of Hearing with Reference to Alleged Dangerous and Unsafe Structure and Accessory Structure located at 13 N. Holbrook Street – Public Hearing Date – 3/20/2018 – 6:15 p.m.
- F. Resolution 7-2018 – Notice of Hearing with Reference to Alleged Dangerous and Unsafe Structure located at 523 S. Main Street – Public Hearing Date – 3/20/2018 – 6:15 p.m.

- G. Resolution 8-2018 – Notice of Hearing with Reference to Alleged Dangerous and Unsafe Structure located at 108 W. Oak Street – Public Hearing Date – 3/20/2018 – 6:15 p.m.
- H. Resolution 9-2018 – Notice of Hearing with Reference to Alleged Dangerous and Unsafe Structure and Accessory Structure located at 309 S. Lowman Street – Public Hearing Date – 3/20/2018 – 6:15 p.m.

Bartelsmeyer moved to approve the Consent Agenda. Nichols seconded. All voted aye.

APPROVED CONSENT AGENDA.

APPEARANCE/COMMENTS/PUBLIC HEARING:

- A. **APPEARANCE:** None
- B. **CITIZEN COMMENTS** (Concerning Items Not on Agenda – 3 minute limit per citizen) - None
- C. **PUBLIC HEARINGS:** None

CONSIDERATION:

1. Consideration of appointment to Fort Scott Planning Commission – one City resident – Diane Clay, City Clerk, informed the Commission that there was an opening on the Planning Commission for a City resident. There were two letters of interest received: Josh Jones and Frank Adamson. The Planning Commission met on January 22nd, 2018 and their recommendation was to approve the appointment of Josh Jones.

Parker moved to approve the appointment of Josh Jones to the Planning Commission board for a three year term. Adamson seconded. All voted aye.

APPROVED APPOINTMENT OF JOSH JONES TO THE FORT SCOTT PLANNING COMMISSION FOR A THREE YEAR TERM.

2. Assignment of Charlesworth Contract – James Charlesworth appeared before the Commission and informed them that his company, Charlesworth & Associates has been in existence since 1977. On November 1st, 2017, the company sold to an insurance brokerage firm. He started Charlesworth Consulting, LLC combining the insurance consulting business and their employee benefit business into a new company. He asked for approval to change the name to Charlesworth Consulting, LLC. He will remain the City's insurance broker. This is just an organizational name change.

Mitchell moved to approve the change of name from Charlesworth & Associates to Charlesworth Consulting, LLC. Parker seconded. All voted aye.

APPROVED CHANGE OF NAME FROM CHARLESWORTH & ASSOCIATES TO CHARLESWORTH CONSULTING, LLC. AS THE CITY'S INSURANCE BROKER.

3. Consideration of 2017 Audit Contract with Diehl, Banwart, Bolton – Jon Garrison, Director of Finance, informed the Commission that he is requesting approval of the 2017 Audit Contract with Diehl, Banwart, Bolton, CPA's. The cost of the audit remains the same as the previous year which is \$18,300.

Bartelsmeyer moved to approve the 2017 Audit Contract in the amount of \$18,300 with Diehl, Banwart, Bolton, CPA's. Nichols seconded. All voted aye.

APPROVED 2017 AUDIT CONTRACT IN THE AMOUNT OF \$18,300 WITH DIEHL, BANWART, BOLTON, CPA'S.

4. Consideration to approve KDOT Form TRF 3 – Closeout of Downtown Brick Street and Sidewalk Replacement Project in 2010 - Jon Garrison, Director of Finance, informed the Commission that he is needing the KDOT Form TRF 3 signed by the Mayor which will close out the Downtown Brick Street and Sidewalk Replacement Project from 2010.

Bartelsmeyer moved to approve the signature of the KDOT Form TRF 3 closing out the Downtown Brick Street and Sidewalk Replacement Project from 2010. Mitchell seconded. All voted aye.

APPROVED THE SIGNATURE OF THE KDOT FORM TRF 3 CLOSING OUT THE DOWNTOWN BRICK STREET AND SIDEWALK REPLACEMENT PROJECT FROM 2010.

5. Consideration of increase in Woodland Hills Golf Course fees and change in membership renewal dates – Jon Garrison, Director of Finance, informed the Commission that the Golf Course Advisory Board recently met on February 1st, 2018 and discussed the fees at Woodland Hills Golf Course. Shannon O'Neil, Golf Pro Manager, had surveyed the area courses and their fees and shared them with the board. The Golf Course Advisory Board voted to recommend raising the fees to the following:

	Weekday	Weekend
9 hole green fees	\$10 to \$11	\$12 to \$13
18 hole green fees	\$12 to \$13	\$14 to \$15
Memberships: Single	\$400 to \$440	

Family (4)	\$550 to \$595
Season Golf Cart	\$350 to \$425

It was also recommended by the Golf Course Advisory Board to have all memberships renew on May 1st of each year. All memberships would need to be prorated this first year, and then next May all memberships would have the same renewal date.

Nichols moved to approve the increase in rates at Woodland Hills Golf Course and the change in membership renewal dates. Parker seconded. All voted aye.

APPROVED INCREASE IN RATES AT WOODLAND HILLS GOLF COURSE AND THE CHANGE IN MEMBERSHIP RENEWAL DATES.

Shannon O'Neil, Golf Pro Manager, gave the Commission an update on this last year and the course. There were 9,069 golfers who played the course. There were 127 memberships sold with 90 of the memberships being single, 27 family, 6 junior and 4 with the family recreation pass. The course is listed as one of the top ten courses to play in the State of Kansas.

6. Consideration to reject demolition bids for 1837 E. 1st – Rhonda Dunn, Community Development Director, asked the Commission to reject the demolition bids for 1837 E. 1st Street. This property has recently sold and the new owner plans to demolish the structure that is there and place a new modular home there.

Parker moved to reject the demolition bids at 1837 E. 1st Street. Adamson seconded. All voted aye.

APPROVED TO REJECT THE DEMOLITION BIDS AT 1837 E. 1ST STREET.

7. Consideration of Tourism Center remodel bids – Dave Martin, City Manager asked the Commission to reject the two bids for remodeling the Tourism Center at 231 E. Wall. There were five contractors who attended a pre-bid meeting, but due to the big difference in the bids, it was determined that a bid specification sheet be created by Ag Engineering. This project will be re-bid after the bid specifications are created.

Bartelsmeyer moved to reject the two bids for the remodeling of the Tourism Center to be rebid at a later date. Nichols seconded. All voted aye.

APPROVED TO REJECT THE TWO BIDS FOR THE REMODEL AT THE TOURISM CENTER AT 231 E. WALL TO BE REBID AT A LATER DATE.

8. Discussion of Utility Office hours – Deb Needleman, Human Resource Director, informed the Commission that back in September of 2017 the hours in the Utility Office were altered to 7:30 a.m. to 5:30 p.m. Monday through Thursday and 7:30 a.m. to 12:00 p.m. on Friday and the office was closed on Friday afternoons. There is quite a lot of people who want to come into City Hall and pay their utility bills on Friday afternoons and the telephone also rings a lot. She asked the Commission to allow the hours to return back to 8:00 a.m. to 5:00 p.m. Monday through Friday effective February 26th, 2018.

Mitchell moved to move the Utility Office hours back to 8:00 a.m. to 5:00 p.m. Monday through Friday effective February 26th, 2018. Parker seconded. All voted aye.

APPROVED TO MOVE THE UTILITY OFFICE HOURS BACK TO 8:00 A.M. TO 5:00 P.M. MONDAY THROUGH FRIDAY EFFECTIVE FEBRUARY 26TH, 2018.

9. Consideration of tree removal from the west and south end of runway – Fort Scott Municipal Airport – Rachel Pruitt and Kenny Howard appeared before the Commission to request permission for tree removal from the west side and the south end of the Airport runway. This would be done by an in-kind donation and the City would not be out any money or time. If the Airport expansion project is approved and funded, these trees would need to be removed as part of the project. If the trees are removed at the present time, it would be before any environmentalals would be needed. This is City property where the trees would be removed.

Bartelsmeyer moved to approve the removal of the trees from the west and south end of the runway. Parker seconded. All voted aye.

APPROVED THE REMOVAL OF TREES FROM THE WEST AND SOUTH END OF THE RUNWAY AT THE AIRPORT FROM AN IN-KIND DONATION.

COMMISSION/STAFF:

- A. Director Updates:** Paul Ballou, Fire Chief, gave the Commission an end of the year end update from 2017. They had almost 1,600 calls. There were more EMS calls and more transfers to area hospitals due to the closure of the ICU unit at Mercy. January 2018 has been very busy so far and more than 40 calls over 2017 have already occurred.

He also gave an update on the Dispatch enter and that the 1st week of March the Next Generation 911 will be installed. There are 60 to 70 centers in Kansas that are hosted through a system in Topeka. Texting to 911 will be offered also and 911 calls will be much easier to trace and follow.

Rhonda Dunn – Stout Building update – Rhonda updated the Commission and shared photos of the Stout building and the condition it is in. There are two large holes in the roof and the building is open to the elements. She received an estimate to have the roof repaired and the building boarded up and it was about \$32,000. There could be some possible interest in the building and she is looking into that. Another option is demolition of the building. It is owned by the Rosalee Stout Trust. More information will be forthcoming.

Chad Brown – Chad shared photos of the City's bucket truck. The City has two bucket trucks, one of which was donated from the County. The smaller bucket truck is used on a daily basis but is having issues with the aerial lift unit. It is costing quite a bit to repair it. He found a 2010 International C4900 truck with 176,000 on Purple Wave for \$12,500 currently for bid. They actually have two of these trucks – one is a 2009 and one is a 2010 and they are both at \$12,500. He asked for approval to spend up to \$25,000 to purchase one of these trucks to replace the bucket truck the City currently has. The City's current bucket truck, which is having issues with the aerial lift, will have the lift removed and the truck will be used on a daily basis as the truck is still in good condition. He and Tom Coffman, the City's mechanic, will travel to Edmond, Oklahoma to look at the bucket truck tomorrow, February 7th, 2018.

Nichols moved to authorize up to \$25,000 to be bid on the 2009 International or 2010 International bucket truck on Purple Wave. Bartelsmeyer seconded. All voted aye.

APPROVED TO AUTHORIZE UP TO \$25,000 TO BE BID ON THE 2009 INTERNATIONAL OR 2010 INTERNATIONAL BUCKET TRUCK ON PURPLE WAVE.

B. City Commission:

Adamson – Nothing to report.

Bartelsmeyer – Nothing to report.

Nichols – Remarked that he likes the Director updates.

Parker – Asked about the stop lights at 3rd and National and if they can be changed to a four way stop.

Chad will check into this. He was waiting for warmer weather to change the intersection and 3rd at National.

Mitchell – Nothing to report.

C. City Attorney: Nothing to report.

D. Director of Finance: Remarked that he is looking at changes in the Utility billing system. The billing used to be broke out into five different billings and the City was split into four quadrants. He would like to merge all the billing into one billing group. There will be some changes made to the current ordinances before this can take place.

Jon also remarked that he and the City Manager have been having meetings with the City's software company, Tyler Technologies, on issues we have been having.

E. City Manager: Nothing to report.

ADJOURNMENT:

Bartelsmeyer moved to adjourn the meeting at 7:29 p.m. Adamson seconded. All voted aye.

ADJOURNED MEETING AT 7:29 P.M.

The next regularly scheduled meeting is to be held on February 20th, 2018 at 6:00 p.m.

RECORDED BY:

DIANE K. CLAY
CITY CLERK



Fort Scott, KS

My Check Report

By Check Number

Date Range: 02/03/2018 - 02/16/2018

Vendor Number	Vendor Name	Payment Date	Payment Type	Discount Amount	Payment Amount	Number
58675	ACCURATE ENVIRONMENTAL	02/07/2018	Regular	0.00	415.14	55435
Payable #	Payable Type	Post Date	Payable Description	Discount Amount	Payable Amount	
SU27614	Invoice	01/24/2018	TURBIDITY STANDARDS CALIBRATION KIT	0.00	195.30	
	711-500-743000		OPERATING SUPPLIES		195.30	
SU27668	Invoice	02/01/2018	CALIBRATION GAS MIXTURE / WWC	0.00	219.84	
	712-550-742000		EQUIPMENT / VEHICLE M		219.84	
			CALIBRATION GAS MIXTURE / W			
45992	CITY OF FORT SCOTT	02/07/2018	Regular	0.00	22.78	55436
Payable #	Payable Type	Post Date	Payable Description	Discount Amount	Payable Amount	
10-2353-02 (01-1	Invoice	01/17/2018	SVC: 12-07-17 TO 01-09-18 (1311 S NATIO	0.00	22.78	
	309-400-723000		UTILITY - WATER		22.78	
			SVC: 12-07-17 TO 01-09-18 (131			
63765	FERGUSON ENTERPRISES INC	02/07/2018	Regular	0.00	1,445.58	55437
Payable #	Payable Type	Post Date	Payable Description	Discount Amount	Payable Amount	
565874	Invoice	01/23/2018	(12) 36X4 METER PIT INSULATORS / WAT	0.00	1,445.58	
	711-510-743000		OPERATING SUPPLIES		1,445.58	
			(12) 36X4 METER PIT INSULATO			
65278	H&A MEDIA GROUP	02/07/2018	Regular	0.00	1,360.00	55438
Payable #	Payable Type	Post Date	Payable Description	Discount Amount	Payable Amount	
0118MWTR3439	Invoice	01/30/2018	16V-2.25"X4" FOUR COLOR AD / AAA MID	0.00	1,360.00	
	208-165-727002		ADVERTISING		1,360.00	
			16V-2.25"X4" FOUR COLOR AD /			
10005	J P COOKE COMPANY	02/07/2018	Regular	0.00	155.50	55439
Payable #	Payable Type	Post Date	Payable Description	Discount Amount	Payable Amount	
492566	Invoice	01/23/2018	(1,000) RED CITY DOG TAGS & (1,000) O-R	0.00	155.50	
	100-230-750000		MISCELLANEOUS COMM		155.50	
			(1,000) RED CITY DOG TAGS & (1			
56658	KANSAS ASSN FOR COURT MGMT	02/07/2018	Regular	0.00	50.00	55440
Payable #	Payable Type	Post Date	Payable Description	Discount Amount	Payable Amount	
01032018	Invoice	01/03/2018	2018 REGULAR COURT MANAGEMENT M	0.00	50.00	
	100-170-726000		DUES AND MEMBERSHIP		50.00	
			2018 REGULAR COURT MANAG			
54385	KANSAS GAS SERVICE	02/07/2018	Regular	0.00	231.12	55441
Payable #	Payable Type	Post Date	Payable Description	Discount Amount	Payable Amount	
510297929 1186	Invoice	01/25/2018	SVC: 12-14-17 TO 01-16-18 (1311 S NATIO	0.00	231.12	
	309-400-723001		UTILITY - GAS		231.12	
			SVC: 12-14-17 TO 01-16-18 (131			
64973	MERCY CLINIC	02/07/2018	Regular	0.00	323.66	55442
Payable #	Payable Type	Post Date	Payable Description	Discount Amount	Payable Amount	
01122018	Invoice	01/19/2018	WORK COMP . . PAID BY CITY	0.00	19.00	
	204-300-727012		CONTRACTUAL SERVICES		19.00	
			WORK COMP . . PAID BY CITY			
01122018-1	Invoice	01/23/2018	WORK COMP . . PAID BY CITY	0.00	93.00	
	204-300-727012		CONTRACTUAL SERVICES		93.00	
			WORK COMP . . PAID BY CITY			
32000110048901	Invoice	02/01/2018	NEGOTIATED RATE	0.00	105.83	

My Check Report

Date Range: 02/03/2018 - 02/16/2018

Vendor Number	Vendor Name	Payment Date	Payment Type	Discount Amount	Payment Amount	Number
	100-200-727000		PRISONER CARE		105.83	
3200011969501	Invoice	02/01/2018	NEGOTIATED RATE	0.00	105.83	
	100-200-727000		PRISONER CARE		105.83	
64955	MERCY HOSPITAL P C	02/07/2018	Regular	0.00	1,705.29	55443
Payable #	Payable Type	Post Date	Payable Description	Discount Amount	Payable Amount	
	Account Number		Account Name		Distribution Amount	
01122018	Invoice	01/23/2018	WORK COMP . . PAID BY CITY	0.00	296.00	
	204-300-727012		CONTRACTUAL SERVICES		296.00	
3200011004900	Invoice	02/01/2018	NEGOTIATED RATE	0.00	341.51	
	100-200-727000		PRISONER CARE		341.51	
3200011025500	Invoice	02/01/2018	NEGOTIATED RATE	0.00	417.58	
	100-200-727000		PRISONER CARE		417.58	
3200011025501	Invoice	02/01/2018	NEGOTIATED RATE	0.00	224.88	
	100-200-727000		PRISONER CARE		224.88	
3200011025700	Invoice	02/01/2018	NEGOTIATED RATE	0.00	160.00	
	100-200-727000		PRISONER CARE		160.00	
3200011969500	Invoice	02/01/2018	NEGOTIATED RATE	0.00	265.32	
	100-200-727000		PRISONER CARE		265.32	
62473	MERCY KANSAS	02/07/2018	Regular	0.00	384.00	55444
Payable #	Payable Type	Post Date	Payable Description	Discount Amount	Payable Amount	
	Account Number		Account Name		Distribution Amount	
605433785	Invoice	01/17/2018	VARIOUS SCREENINGS & TESTINGS	0.00	384.00	
	100-210-727012		CONTRACTUAL SERVICES		80.00	
	100-220-727012		CONTRACTUAL SERVICES		64.00	
	100-420-727012		CONTRACTUAL SERVICES		20.00	
	204-300-727012		CONTRACTUAL SERVICES		60.00	
	711-510-727012		CONTRACTUAL SERVICES		20.00	
	711-520-727012		CONTRACTUAL SERVICES		20.00	
	712-540-727012		CONTRACTUAL SERVICES		60.00	
	712-550-727012		CONTRACTUAL SERVICES		40.00	
	719-560-727012		CONTRACTUAL SERVICES		20.00	
13440	MILLER FEED & OIL INC	02/07/2018	Regular	0.00	22.98	55445
Payable #	Payable Type	Post Date	Payable Description	Discount Amount	Payable Amount	
	Account Number		Account Name		Distribution Amount	
61498	Invoice	01/17/2018	GLOVES / STREET DEPT	0.00	22.98	
	204-300-750000		MISCELLANEOUS COMM		22.98	
65291	PIONEER NETWORK INC	02/07/2018	Regular	0.00	4,563.00	55446
Payable #	Payable Type	Post Date	Payable Description	Discount Amount	Payable Amount	
	Account Number		Account Name		Distribution Amount	
1604	Invoice	01/26/2018	(2) GALAXY LEATHER CHAIRS FOR DISPATC	0.00	4,563.00	
	100-220-764000		MACHINERY AND EQUIP		4,563.00	
62464	SECURITY 1ST TITLE LLC	02/07/2018	Regular	0.00	50.00	55447
Payable #	Payable Type	Post Date	Payable Description	Discount Amount	Payable Amount	
	Account Number		Account Name		Distribution Amount	
2242749	Invoice	01/26/2018	LGL DSCRPTN/LOT 1-12,BLK 5,MCMILLAN'	0.00	50.00	
	100-240-727001		LEGAL FEES		50.00	
19489	SOUTHEAST KANSAS EDUCATION	02/07/2018	Regular	0.00	335.00	55448

My Check Report

Date Range: 02/03/2018 - 02/16/2018

Vendor Number	Vendor Name	Payment Date	Payment Type	Discount Amount	Payment Amount	Number
Payable #	Payable Type	Post Date	Payable Description	Discount Amount	Payable Amount	
	Account Number	Account Name	Item Description	Distribution Amount		
126523	Invoice	01/18/2018	ADMINISTRATION FEES	0.00	335.00	
	100-110-713000		ADMINISTRATION FEE		5.00	
	100-120-713000		ADMINISTRATION FEE		5.00	
	100-130-713000		ADMINISTRATION FEE		15.00	
	100-140-713000		ADMINISTRATION FEE		5.00	
	100-150-713000		ADMINISTRATION FEE		5.00	
	100-200-713000		ADMINISTRATION FEE		75.00	
	100-220-713000		ADMINISTRATION FEE		35.00	
	100-230-713000		ADMINISTRATION FEE		5.00	
	100-240-713000		ADMINISTRATION FEE		15.00	
	100-310-713000		ADMINISTRATION FEE		10.00	
	100-400-713000		ADMINISTRATION FEE		10.00	
	100-405-713000		ADMINISTRATION FEE		5.00	
	100-420-713000		ADMINISTRATION FEE		15.00	
	204-300-713000		ADMINISTRATION FEE		40.00	
	208-165-713000		ADMINISTRATION FEE		10.00	
	711-500-713000		ADMINISTRATION FEE		25.00	
	711-510-713000		ADMINISTRATION FEE		20.00	
	711-520-713000		ADMINISTRATION FEE		5.00	
	712-540-713000		ADMINISTRATION FEE		15.00	
	712-550-713000		ADMINISTRATION FEE		5.00	
	712-555-713000		ADMINISTRATION FEE		5.00	
	719-560-713000		ADMINISTRATION FEE		5.00	
	Void	02/07/2018	Regular	0.00	0.00	55449
58560	VANTAGEPOINT TRANSFER	02/09/2018	Regular	0.00	89.95	55458
Payable #	Payable Type	Post Date	Payable Description	Discount Amount	Payable Amount	
Account Number	Account Name	Item Description	Distribution Amount			
INV0003144	Invoice	02/09/2018	Deferred Comp - 303141	0.00	89.95	
	100-000-202000		PAYROLL LIABILITY CLEARI		89.95	
65050	CARE TO SHARE	02/09/2018	Regular	0.00	500.00	55460
Payable #	Payable Type	Post Date	Payable Description	Discount Amount	Payable Amount	
Account Number	Account Name	Item Description	Distribution Amount			
02062018	Invoice	02/07/2018	DONATION . . . ROTARY - DWOS	0.00	500.00	
	100-190-727012		CONTRACTUAL SERVICES		500.00	
65323	DEE REGINA	02/09/2018	Regular	0.00	30.00	55461
Payable #	Payable Type	Post Date	Payable Description	Discount Amount	Payable Amount	
Account Number	Account Name	Item Description	Distribution Amount			
01082018	Invoice	02/08/2018	ANIMAL ADOPTION	0.00	30.00	
	100-000-452000		ANIMAL ADOPTION FEES		30.00	
05130	ETTINGERS	02/09/2018	Regular	0.00	43.50	55462
Payable #	Payable Type	Post Date	Payable Description	Discount Amount	Payable Amount	
Account Number	Account Name	Item Description	Distribution Amount			
499856-0	Invoice	02/06/2018	(2) NOTARY STAMPS / DISPATCH	0.00	43.50	
	100-220-744000		OFFICE SUPPLIES		43.50	
06250	FORT SCOTT LUMBER INC	02/09/2018	Regular	0.00	226.84	55463
Payable #	Payable Type	Post Date	Payable Description	Discount Amount	Payable Amount	
Account Number	Account Name	Item Description	Distribution Amount			
31220	Invoice	01/17/2018	SHEETROCK & DRYWALL SCREWS / AIRPO	0.00	13.48	
	100-310-741000		BUILDING MAINTENANCE		13.48	
31406	Invoice	01/17/2018	2-1/4 PRIMED COLONIAL CASE / BUNKRO	0.00	53.55	
	100-210-741000		BUILDING MAINTENANCE		53.55	
31509	Invoice	01/19/2018	HARDWARE / STREET DEPT	0.00	25.90	
	204-300-750000		MISCELLANEOUS COMM		25.90	

My Check Report

Date Range: 02/03/2018 - 02/16/2018

Vendor Number	Vendor Name	Payment Date	Payment Type	Discount Amount	Payment Amount	Number
31586	Invoice 711-510-743000	01/23/2018	LUMBER, CUT-OFF BLADE, CUT BLADE / W OPERATING SUPPLIES LUMBER, CUT-OFF BLADE, CUT	0.00	59.47	
31591	Invoice 711-510-743000	01/23/2018	HARDWARE / WATER DIST OPERATING SUPPLIES HARDWARE / WATER DIST	0.00	11.70	
31598	Invoice 711-510-743000	01/23/2018	HARDWARE / WATER DIST OPERATING SUPPLIES HARDWARE / WATER DIST	0.00	4.40	
31601	Invoice 711-510-743000	01/23/2018	SAW BLADE & LUMBER / WATER DIST OPERATING SUPPLIES SAW BLADE & LUMBER / WATER	0.00	8.44	
31785	Invoice 711-510-743000	02/07/2018	(3) 80# CONCRETE MIX W/SAND & GRAV OPERATING SUPPLIES (3) 80# CONCRETE MIX W/SAN	0.00	13.49	
31791	Invoice 711-510-743000	02/07/2018	(5) 80# CONCRETE MIX W/SAND & GRAV OPERATING SUPPLIES (5) 80# CONCRETE MIX W/SAN	0.00	22.48	
31813	Invoice 204-300-743000	02/07/2018	LUMBER / STREET DEPT OPERATING SUPPLIES LUMBER / STREET DEPT	0.00	13.93	
06265	FORT SCOTT RECREATION COMMISSION	02/09/2018	Regular	0.00	405.00	55464
Payable #	Payable Type	Post Date	Payable Description	Discount Amount	Payable Amount	
02012018	Invoice 100-000-472000	02/06/2018	RECREATION PAYMENT (01-26-18 THRU 0 RECREATION COMMISSIO RECREATION PAYMENT (01-26-1	0.00	405.00	
65322	JERRY A WITT	02/09/2018	Regular	0.00	6,622.64	55465
Payable #	Payable Type	Post Date	Payable Description	Discount Amount	Payable Amount	
01312018	Invoice 203-160-734000	02/08/2018	DOWNTOWN GRANT PROJECT GRANTS DOWNTOWN GRANT PROJECT	0.00	6,622.64	
65001	JILL GORMAN	02/09/2018	Regular	0.00	2,000.00	55466
Payable #	Payable Type	Post Date	Payable Description	Discount Amount	Payable Amount	
02072018	Invoice 100-240-727014	02/09/2018	SIDEWALK, CURB & GUTTER REPLACEME SIDEWALK REIMBURSEM SIDEWALK, CURB & GUTTER REP	0.00	2,000.00	
11010	K & K AUTO PARTS INC	02/09/2018	Regular	0.00	5,116.05	55467
Payable #	Payable Type	Post Date	Payable Description	Discount Amount	Payable Amount	
46108	Invoice 711-500-742000	01/17/2018	PART FOR UNIT 620 / WTP EQUIPMENT / VEHICLE M PART FOR UNIT 620 / WTP	0.00	115.00	
46109	Invoice 712-550-742000	01/17/2018	HYDRAULIC FILTERS, OIL FILTER, OIL (UNIT EQUIPMENT / VEHICLE M HYDRAULIC FILTERS, OIL FILTER,	0.00	142.01	
46114	Invoice 204-300-742000	01/17/2018	FEMALE COUPLER, HYD HOSE, HOSE FITTIN EQUIPMENT / VEHICLE M FEMALE COUPLER, HYD HOSE, H	0.00	94.90	
46115	Invoice 100-230-742000	01/17/2018	BATTERY (UNIT 134) EQUIPMENT / VEHICLE M BATTERY (UNIT 134)	0.00	114.11	
46116	Invoice 204-300-742000	01/17/2018	(12) BRAKE CLEANER / STREET DEPT EQUIPMENT / VEHICLE M (12) BRAKE CLEANER / STREET D	0.00	40.20	
46200	Invoice 100-210-742000	01/17/2018	DIESEL FUEL CONDITIONER & SEA FOAM EQUIPMENT / VEHICLE M DIESEL FUEL CONDITIONER & SE	0.00	100.25	
46201	Invoice 100-210-742000	01/17/2018	GRILLE BRUSH GUARD (RESCUE 1 . . FSPD) EQUIPMENT / VEHICLE M GRILLE BRUSH GUARD (RESCUE	0.00	1,295.00	
46220	Invoice 711-500-742000	01/17/2018	12-VOLT GOLF CART BATTERY / WTP EQUIPMENT / VEHICLE M 12-VOLT GOLF CART BATTERY /	0.00	679.00	
46221	Invoice 204-300-742000	01/17/2018	CLUSTER 599-667 (UNIT 113) EQUIPMENT / VEHICLE M CLUSTER 599-667 (UNIT 113)	0.00	245.00	
46295	Invoice	01/17/2018	ANTI-GEL & DIESEL 911 / WATER DIST	0.00	18.06	

My Check Report

Date Range: 02/03/2018 - 02/16/2018

Vendor Number	Vendor Name	Payment Date	Payment Type	Discount Amount	Payment Amount	Number
	711-510-742000		EQUIPMENT / VEHICLE M ANTI-GEL & DIESEL 911 / WATER		18.06	
46296	Invoice	01/17/2018	SKT 3/8 DR DP 6P & WALK BEHIND CONC	0.00	62.89	
	204-300-742000		EQUIPMENT / VEHICLE M WALK BEHIND CONCRETE SAW /		49.95	
	204-300-750000		MISCELLANEOUS COMM SKT 3/8 DR DP 6P / STREET DEP		12.94	
46313	Invoice	01/17/2018	BEARINGS (UNIT 257 SPREADER)	0.00	34.36	
	204-300-742000		EQUIPMENT / VEHICLE M BEARINGS (UNIT 257 SPREADER		34.36	
46354	Invoice	01/19/2018	BULB,AIR FILTER,OIL FILTER,OIL (RESCUE 1	0.00	49.06	
	100-210-742000		EQUIPMENT / VEHICLE M BULB,AIR FILTER,OIL FILTER,OIL (49.06	
46356	Invoice	01/19/2018	OIL FILTER, FUEL FILTER, OIL (ENGINE #1 -	0.00	134.78	
	100-210-742000		EQUIPMENT / VEHICLE M OIL FILTER, FUEL FILTER, OIL (EN		134.78	
46411	Invoice	01/23/2018	(4) ADAPTERS, GLOVES, DIESEL FUEL CON	0.00	114.25	
	204-300-742000		EQUIPMENT / VEHICLE M (4) ADAPTERS (UNIT 255)		20.80	
	204-300-750000		MISCELLANEOUS COMM LEATHER GLOVES		16.95	
	711-510-742000		EQUIPMENT / VEHICLE M DIESEL FUEL CONDITIONER (UNI		76.50	
46426	Invoice	01/23/2018	MALE TIP & FEMALE COUPLER PIONEER (0.00	29.70	
	204-300-742000		EQUIPMENT / VEHICLE M MALE TIP & FEMALE COUPLER P		29.70	
46454	Invoice	01/25/2018	GREASE,(12) BRAKE CLEANER,GASKET MA	0.00	54.76	
	100-400-742000		EQUIPMENT / VEHICLE M GREASE,(12) BRAKE CLEANER,G		54.76	
46456	Invoice	01/25/2018	FAN CLUTCH (UNIT 220)	0.00	337.90	
	204-300-742000		EQUIPMENT / VEHICLE M FAN CLUTCH (UNIT 220)		337.90	
46462	Invoice	01/25/2018	OIL FILTER, FUEL FILTER, (6) OIL (UNIT 135	0.00	32.26	
	100-200-742000		EQUIPMENT / VEHICLE M OIL FILTER, FUEL FILTER, (6) OIL (32.26	
46476	Invoice	01/30/2018	FEMALE COUPLER & (2) MALE TIP O-RING	0.00	118.85	
	711-510-742000		EQUIPMENT / VEHICLE M FEMALE COUPLER & (2) MALE TI		118.85	
46477	Invoice	01/30/2018	(12) BRAKE CLEANER (UNIT 282) / PARKS	0.00	41.88	
	100-400-742000		EQUIPMENT / VEHICLE M (12) BRAKE CLEANER (UNIT 282)		41.88	
46498	Invoice	02/06/2018	3/8 IMPACT SOCKET SET / STREET DEPT	0.00	130.00	
	204-300-750000		MISCELLANEOUS COMM 3/8 IMPACT SOCKET SET / STREE		130.00	
46500	Invoice	01/30/2018	(3) HINGE PINS / WATER DIST	0.00	25.77	
	711-510-742000		EQUIPMENT / VEHICLE M (3) HINGE PINS / WATER DIST		25.77	
46550	Invoice	02/06/2018	(2) POWER STEERING FLUID / PARKS DEPT	0.00	8.10	
	100-400-742000		EQUIPMENT / VEHICLE M (2) POWER STEERING FLUID / PA		8.10	
46596	Invoice	02/06/2018	POWER STEERING FLUID / PARKS DEPT	0.00	4.05	
	100-400-742000		EQUIPMENT / VEHICLE M POWER STEERING FLUID / PARK		4.05	
46605	Invoice	02/06/2018	3/8 IMPACT SOCKET SET & PAPER TOWEL	0.00	137.93	
	204-300-750000		MISCELLANEOUS COMM 3/8 IMPACT SOCKET SET & PAPE		137.93	
46606	Invoice	02/06/2018	WIRE HOSE & HOSE FITTINGS (UNIT 423)	0.00	128.44	
	204-300-742000		EQUIPMENT / VEHICLE M WIRE HOSE & HOSE FITTINGS (U		128.44	
46644	Invoice	02/06/2018	CUMMINS BOLT SET & ENGINE KIT (UNIT	0.00	637.61	
	100-400-742000		EQUIPMENT / VEHICLE M CUMMINS BOLT SET & ENGINE		637.61	
46645	Invoice	02/06/2018	(2) TOWELS IN A BOX / STREET DEPT	0.00	39.98	
	204-300-750000		MISCELLANEOUS COMM (2) TOWELS IN A BOX / STREET		39.98	
46646	Invoice	02/06/2018	NEW STARTER / GOLF COURSE GATOR	0.00	149.95	
	100-420-742000		EQUIPMENT / VEHICLE M NEW STARTER / GOLF COURSE		149.95	
	Void	02/09/2018	Regular	0.00	0.00	55468
	Void	02/09/2018	Regular	0.00	0.00	55469
11093	KANSAS DEPARTMENT OF REVENUE	02/09/2018	Regular	0.00	30.00	55470
Payable #	Payable Type	Post Date	Payable Description	Discount Amount	Payable Amount	
	Account Number		Account Name		Distribution Amount	
01312018	Invoice	02/06/2018	(3) MVRS FOR JANUARY 2018	0.00	30.00	
	100-000-291007		MVR FEE		30.00	
65288	MCINROY CONTRACTORS LLC	02/09/2018	Regular	0.00	53,845.26	55471

My Check Report

Date Range: 02/03/2018 - 02/16/2018

Vendor Number	Vendor Name	Payment Date	Payment Type	Discount Amount	Payment Amount	Number
Payable #	Payable Type	Post Date	Payable Description	Discount Amount	Payable Amount	
	Account Number	Account Name	Item Description	Distribution Amount		
1 (01-18-18)	Invoice 324-510-763000	02/09/2018	REHAB OF COLLEGE BOOSTER PUMP STAT IMPROVEMENTS	0.00	53,845.26	
15087	O REILLY AUTO PARTS	02/09/2018	Regular	0.00	871.66	55472
198-392042	Invoice 204-300-742000	01/17/2018	DIESEL SUPPLEMENT (UNIT 290) EQUIPMENT / VEHICLE M DIESEL SUPPLEMENT (UNIT 290)	0.00	17.99	
198-392089	Invoice 204-300-742000	01/17/2018	FUEL FILTER (UNIT 290) EQUIPMENT / VEHICLE M FUEL FILTER (UNIT 290)	0.00	54.54	
198-392357	Invoice 100-420-742000	01/17/2018	HYDRAULIC FILTER & FUEL FILTER / GOLF EQUIPMENT / VEHICLE M HYDRAULIC FILTER & FUEL FILTE	0.00	38.40	
198-392458	Invoice 100-400-743000	01/17/2018	PAINT . . . FOR DOWNTOWN TRASH CANS OPERATING SUPPLIES PAINT . . . FOR DOWNTOWN TR	0.00	100.34	
198-392460	Invoice 100-310-742000	01/17/2018	(6) ANTI-FREEZE / AIRPORT EQUIPMENT / VEHICLE M (6) ANTI-FREEZE / AIRPORT	0.00	35.94	
198-392466	Invoice 100-310-742000	01/17/2018	(2) ANTI-FREEZE / AIRPORT EQUIPMENT / VEHICLE M (2) ANTI-FREEZE / AIRPORT	0.00	29.98	
198-392802	Invoice 204-300-742000	01/17/2018	ADHESIVE / STREET DEPT EQUIPMENT / VEHICLE M ADHESIVE / STREET DEPT	0.00	14.40	
198-392921	Invoice 711-510-742000	01/18/2018	MARKER LIGHT / WATER DIST EQUIPMENT / VEHICLE M MARKER LIGHT / WATER DIST	0.00	4.79	
198-392940	Invoice 100-420-750000	01/17/2018	(3) MOTOR OIL / GOLF COURSE OIL FOR S MISCELLANEOUS COMM (3) MOTOR OIL / GOLF COURSE	0.00	83.97	
198-392988	Invoice 204-300-742000	01/17/2018	HYDRO-BOOST & CORE CHARGE (UNIT 52 EQUIPMENT / VEHICLE M HYDRO-BOOST & CORE CHARGE	0.00	206.19	
198-393068	Invoice 204-300-742000	01/17/2018	(2) WIPER FLUID / STREET DEPT EQUIPMENT / VEHICLE M (2) WIPER FLUID / STREET DEPT	0.00	9.58	
198-393134	Invoice 711-510-742000	01/17/2018	STEERING WHEEL COVER / WATER DIST EQUIPMENT / VEHICLE M STEERING WHEEL COVER / WAT	0.00	9.99	
198-393149	Credit Memo 204-300-742000	01/17/2018	**CORE RETURN** (ORIG INV #198-3929 EQUIPMENT / VEHICLE M **CORE RETURN** (ORIG INV #	0.00	-13.00	
198-393181	Invoice 711-510-743000	01/17/2018	(2) PENETRANT / WATER DIST OPERATING SUPPLIES (2) PENETRANT / WATER DIST	0.00	11.18	
198-393211	Invoice 100-420-750000	01/17/2018	RATCHET & REPL TIPS / GOLF COURSE SH MISCELLANEOUS COMM RATCHET & REPL TIPS / GOLF CO	0.00	16.98	
198-393236	Invoice 204-300-742000	02/07/2018	(2) FUEL FILTERS (DROPPED TO CITY BY MI EQUIPMENT / VEHICLE M (2) FUEL FILTERS (DROPPED TO	0.00	14.28	
198-393241	Invoice 204-300-742000	01/17/2018	SPOT MIRROR / STREET DEPT EQUIPMENT / VEHICLE M SPOT MIRROR / STREET DEPT	0.00	3.49	
198-393261	Credit Memo 204-300-742000	02/07/2018	*CR* FUEL FLTRS DROPPED TO CITY BY M EQUIPMENT / VEHICLE M *CR* FUEL FLTRS DROPPED TO	0.00	-14.28	
198-393265	Invoice 100-400-743000	01/17/2018	MOTOR TREATMENT / PARKS DEPT OPERATING SUPPLIES MOTOR TREATMENT / PARKS DE	0.00	10.79	
198-393706	Invoice 711-510-742000	01/17/2018	6-PK PAPER & STARTING FLUID / WATER D EQUIPMENT / VEHICLE M 6-PK PAPER & STARTING FLUID /	0.00	8.68	
198-393892	Invoice 711-510-742000	01/18/2018	(2) WIPER BLADES / WATER DIST EQUIPMENT / VEHICLE M (2) WIPER BLADES / WATER DIST	0.00	37.96	
198-394460	Invoice 100-420-742000	01/23/2018	AIR FILTER / GOLF COURSE UTILITY VEHIC EQUIPMENT / VEHICLE M AIR FILTER / GOLF COURSE UTILI	0.00	11.23	
198-394572	Invoice	01/30/2018	ADAPTER / WATER DIST	0.00	17.99	

My Check Report

Date Range: 02/03/2018 - 02/16/2018

Vendor Number	Vendor Name	Payment Date	Payment Type	Discount Amount	Payment Amount	Number
	711-510-742000		EQUIPMENT / VEHICLE M ADAPTER / WATER DIST		17.99	
198-394669	Invoice	01/25/2018	BLOWER MOTOR (UNIT 223)	0.00	45.68	
	204-300-742000		EQUIPMENT / VEHICLE M BLOWER MOTOR (UNIT 223)		45.68	
198-394670	Invoice	01/25/2018	BLOWER RESISTOR (UNIT 223)	0.00	11.16	
	204-300-742000		EQUIPMENT / VEHICLE M BLOWER RESISTOR (UNIT 223)		11.16	
198-394671	Invoice	01/24/2018	BATTERY-CORE EXCHANGE, SHOP TOWELS	0.00	58.93	
	100-420-742000		EQUIPMENT / VEHICLE M BATTERY-CORE EXCHANGE, SHO		58.93	
198-394896	Invoice	01/26/2018	(2) HYDRAULIC FILTERS	0.00	44.48	
	100-420-742000		EQUIPMENT / VEHICLE M (2) HYDRAULIC FILTERS		44.48	
	Void	02/09/2018	Regular	0.00	0.00	55473
65137	OZARK PORTABLE BUILDINGS	02/09/2018	Regular	0.00	2,788.00	55474
Payable #	Payable Type	Post Date	Payable Description	Discount Amount	Payable Amount	
	Account Number		Account Name		Distribution Amount	
02052018	Invoice	02/06/2018	10' X 16' OZARK BUILDING / DOG POUND	0.00	2,788.00	
	100-230-762000		BUILDINGS		2,788.00	
55815	SUDDENLINK	02/09/2018	Regular	0.00	187.04	55475
Payable #	Payable Type	Post Date	Payable Description	Discount Amount	Payable Amount	
	Account Number		Account Name		Distribution Amount	
708409601 (02-0	Invoice	02/07/2018	2018 OPEN PO / 23 S FRANKLIN-FSFD / AC	0.00	187.04	
	100-210-723003		UTILITY - CABLE		187.04	
58112	TRACTOR SUPPLY CREDIT PLAN	02/09/2018	Regular	0.00	610.50	55476
Payable #	Payable Type	Post Date	Payable Description	Discount Amount	Payable Amount	
	Account Number		Account Name		Distribution Amount	
328330	Invoice	01/17/2018	3-PIECE PUMP FITTING / STREET DEPT	0.00	5.99	
	204-300-742000		EQUIPMENT / VEHICLE M 3-PIECE PUMP FITTING / STREET		5.99	
328523	Invoice	01/17/2018	(2 SETS) 85-PIECE CRESCENT SETS / WTP	0.00	119.98	
	711-500-742000		EQUIPMENT / VEHICLE M (2 SETS) 85-PIECE CRESCENT SE		119.98	
328632	Invoice	01/17/2018	KEROSENE BTU HEATER & STOVE PIPE / W	0.00	213.98	
	711-510-743000		OPERATING SUPPLIES KEROSENE BTU HEATER & STOV		213.98	
328755	Invoice	01/17/2018	(2) PROPANE CYLINDERS & GLOVES / WW	0.00	18.49	
	712-540-742000		EQUIPMENT / VEHICLE M (2) PROPANE CYLINDERS & GLO		18.49	
329072	Invoice	01/17/2018	PINE-SOL / AIRPORT	0.00	12.99	
	100-310-745000		JANITORIAL SUPPLIES PINE-SOL / AIRPORT		12.99	
329649	Invoice	01/17/2018	3-PIECE PUMP FITTING / STREET DEPT	0.00	5.99	
	204-300-742000		EQUIPMENT / VEHICLE M 3-PIECE PUMP FITTING / STREET		5.99	
330031	Invoice	01/17/2018	(2) 600-LB HAND TRUCK / WWTP (2-WHE	0.00	60.00	
	712-540-742000		EQUIPMENT / VEHICLE M (2) 600-LB HAND TRUCK / WWT		60.00	
330157	Invoice	01/17/2018	MASKING TAPE / AIRPORT	0.00	4.99	
	100-310-750000		MISCELLANEOUS COMM MASKING TAPE / AIRPORT		4.99	
330927	Invoice	01/23/2018	SPRING CLAMP / AIRPORT	0.00	3.10	
	100-310-742000		EQUIPMENT / VEHICLE M SPRING CLAMP / AIRPORT		3.10	
331480	Invoice	01/23/2018	HIGH BACK TRACTOR SEAT/GOLF COURSE	0.00	164.99	
	100-420-742000		EQUIPMENT / VEHICLE M HIGH BACK TRACTOR SEAT/GOL		164.99	
65276	WIESE USA INC	02/09/2018	Regular	0.00	4,800.77	55477
Payable #	Payable Type	Post Date	Payable Description	Discount Amount	Payable Amount	
	Account Number		Account Name		Distribution Amount	
40298105	Invoice	01/30/2018	FIRE STATION DOOR CONTROLS	0.00	4,800.77	
	100-210-763000		IMPROVEMENTS FIRE STATION DOOR CONTROLS		4,800.77	
57711	AT&T	02/16/2018	Regular	0.00	1,266.49	55492

My Check Report

Date Range: 02/03/2018 - 02/16/2018

Vendor Number	Vendor Name	Payment Date	Payment Type	Discount Amount	Payment Amount	Number
Payable #	Payable Type	Post Date	Payable Description	Discount Amount	Payable Amount	
Account Number	Account Name	Item Description	Distribution Amount			
316 140-0059 42	Invoice	02/15/2018	2018 OPEN PO / TELEPHONE / 316 140-00	0.00	154.28	
	207-220-723004		UTILITY - TELEPHONE		154.28	
316 660-9904 01	Invoice	02/15/2018	2018 OPEN PO / TELEPHONE / 316 660-99	0.00	1,112.21	
	207-220-723004		UTILITY - TELEPHONE		1,112.21	
59112	BIRCH COMMUNICATIONS INC	02/16/2018	Regular	0.00	507.27	55493
Payable #	Payable Type	Post Date	Payable Description	Discount Amount	Payable Amount	
Account Number	Account Name	Item Description	Distribution Amount			
25661528	Invoice	02/06/2018	JANUARY LONG DISTANCE SERVICE	0.00	507.27	
	100-190-723004		UTILITY - TELEPHONE		22.02	
	100-200-723004		UTILITY - TELEPHONE		141.44	
	100-210-723004		UTILITY - TELEPHONE		62.10	
	100-220-723004		UTILITY - TELEPHONE		36.67	
	100-310-723004		UTILITY - TELEPHONE		44.04	
	100-400-723004		UTILITY - TELEPHONE		14.68	
	100-410-723004		UTILITY - TELEPHONE		7.34	
	100-420-723004		UTILITY - TELEPHONE		14.68	
	100-430-723004		UTILITY - TELEPHONE		36.85	
	204-300-723004		UTILITY - TELEPHONE		54.05	
	711-500-723004		UTILITY - TELEPHONE		44.04	
	711-510-723004		UTILITY - TELEPHONE		7.34	
	712-540-723004		UTILITY - TELEPHONE		22.02	
65325	CITY OF PARSONS, TOURISM DEPT	02/16/2018	Regular	0.00	200.00	55494
Payable #	Payable Type	Post Date	Payable Description	Discount Amount	Payable Amount	
Account Number	Account Name	Item Description	Distribution Amount			
02132018	Invoice	02/15/2018	BOOTH COSTS . . . KC BOAT SHOW (JAN 18	0.00	200.00	
	208-165-727002		ADVERTISING		200.00	
63482	DISH	02/16/2018	Regular	0.00	122.95	55495
Payable #	Payable Type	Post Date	Payable Description	Discount Amount	Payable Amount	
Account Number	Account Name	Item Description	Distribution Amount			
8255 7070 8820	Invoice	02/15/2018	2018 OPEN PO/MNTHLY TV & ADD-ONS/L	0.00	122.95	
	100-405-723003		UTILITY - CABLE		122.95	
54849	FBI - LEEDA	02/16/2018	Regular	0.00	100.00	55496
Payable #	Payable Type	Post Date	Payable Description	Discount Amount	Payable Amount	
Account Number	Account Name	Item Description	Distribution Amount			
42379328-18	Invoice	02/14/2018	2018 FBI-LEEDA ANNUAL DUES / JOHN T S	0.00	50.00	
	100-200-726000		DUES AND MEMBERSHIP		50.00	
42397195-18	Invoice	02/14/2018	2018 FBI-LEEDA ANNUAL DUES / SHAUN T	0.00	50.00	
	100-200-726000		DUES AND MEMBERSHIP		50.00	
06190	FORT SCOTT COMMUNITY COLLEGE	02/16/2018	Regular	0.00	1,425.00	55497
Payable #	Payable Type	Post Date	Payable Description	Discount Amount	Payable Amount	
Account Number	Account Name	Item Description	Distribution Amount			
172S-0212B	Invoice	02/13/2018	SPRING 2018 . . . EMT COURSE (T.REED)	0.00	1,425.00	
	100-220-725000		TRAVEL AND TRAINING		1,425.00	
06265	FORT SCOTT RECREATION COMMISSION	02/16/2018	Regular	0.00	250.00	55498
Payable #	Payable Type	Post Date	Payable Description	Discount Amount	Payable Amount	
Account Number	Account Name	Item Description	Distribution Amount			
20740	Invoice	02/15/2018	1/2 OF TEXT CASTER FEES	0.00	250.00	
	100-430-727002		ADVERTISING		250.00	
06265	FORT SCOTT RECREATION COMMISSION	02/16/2018	Regular	0.00	70.00	55499

My Check Report

Date Range: 02/03/2018 - 02/16/2018

Vendor Number	Vendor Name	Payment Date	Payment Type	Discount Amount	Payment Amount	Number
Payable #	Payable Type	Post Date	Payable Description	Discount Amount	Payable Amount	
	Account Number	Account Name	Item Description	Distribution Amount		
02082018	Invoice	02/15/2018	RECREATION PAYMENT (02-02-18 THRU 0	0.00	70.00	
	100-000-472000		RECREATION COMMISSIO		70.00	
65327	HAVENS CONSTRUCTION COMPANY INC	02/16/2018	Regular	0.00	32,851.22	55500
Payable #	Payable Type	Post Date	Payable Description	Discount Amount	Payable Amount	
	Account Number	Account Name	Item Description	Distribution Amount		
9208	Invoice	02/16/2018	SANITARY SEWER REPAIR & MANHOLE IN	0.00	32,851.22	
	712-550-763000		IMPROVEMENTS		32,851.22	
65123	LOCKWORX MOBILE LOCKSMITHING LLC	02/16/2018	Regular	0.00	363.00	55501
Payable #	Payable Type	Post Date	Payable Description	Discount Amount	Payable Amount	
	Account Number	Account Name	Item Description	Distribution Amount		
707017	Invoice	02/14/2018	LOCKS FOR DAVIS / WWTP	0.00	363.00	
	712-540-741000		BUILDING MAINTENANCE		363.00	
23160	WESTAR ENERGY	02/16/2018	Regular	0.00	54,103.66	55502
Payable #	Payable Type	Post Date	Payable Description	Discount Amount	Payable Amount	
	Account Number	Account Name	Item Description	Distribution Amount		
135021	Invoice	02/15/2018	2018 OPEN PO / METER #16752324 @ 91	0.00	6,805.37	
	711-500-723002		UTILITY - ELECTRIC		6,805.37	
1808358260 (02-	Invoice	02/15/2018	JANUARY STREET LIGHTING	0.00	9,015.32	
	100-190-723002		UTILITY - ELECTRIC		9,015.32	
7110122629 (02-	Invoice	02/15/2018	MONTHLY UTILITY SERVICE	0.00	38,282.97	
	100-190-723002		UTILITY - ELECTRIC		3,830.07	
	100-200-723002		UTILITY - ELECTRIC		289.20	
	100-210-723002		UTILITY - ELECTRIC		1,740.31	
	100-310-723002		UTILITY - ELECTRIC		679.46	
	100-400-723002		UTILITY - ELECTRIC		894.33	
	100-405-723002		UTILITY - ELECTRIC		1,277.93	
	100-410-723002		UTILITY - ELECTRIC		121.19	
	100-420-723002		UTILITY - ELECTRIC		1,407.76	
	100-430-723002		UTILITY - ELECTRIC		4,404.63	
	100-430-727019		NEW GYMNASIUM - SPLI		716.64	
	204-300-723002		UTILITY - ELECTRIC		955.40	
	309-400-723002		UTILITY - ELECTRIC		88.12	
	711-500-723002		UTILITY - ELECTRIC		9,907.48	
	711-510-723002		UTILITY - ELECTRIC		318.08	
	711-530-723002		UTILITY - ELECTRIC		163.82	
	712-540-723002		UTILITY - ELECTRIC		11,488.55	
	Void	02/16/2018	Regular	0.00	0.00	55503
54731	4STATE MAINTENANCE SUPPLY CO	02/07/2018	EFT	0.00	821.78	2003443
Payable #	Payable Type	Post Date	Payable Description	Discount Amount	Payable Amount	
	Account Number	Account Name	Item Description	Distribution Amount		
559401	Invoice	01/23/2018	JANITORIAL SUPPLIES / LAROCHE BALLFIE	0.00	821.78	
	100-405-745000		JANITORIAL SUPPLIES		821.78	
55706	ASSESSMENT STRATEGIES LLC	02/07/2018	EFT	0.00	525.00	2003444
Payable #	Payable Type	Post Date	Payable Description	Discount Amount	Payable Amount	
	Account Number	Account Name	Item Description	Distribution Amount		
02012018	Invoice	02/01/2018	JAN 5, 9, 11 . . PERSONNEL TESTING	0.00	525.00	
	100-200-727012		CONTRACTUAL SERVICES		525.00	
59610	BREATHING AIR SERVICES INC	02/07/2018	EFT	0.00	1,354.40	2003445

My Check Report

Date Range: 02/03/2018 - 02/16/2018

Vendor Number	Vendor Name	Payment Date	Payment Type	Discount Amount	Payment Amount	Number
Payable #	Payable Type	Post Date	Payable Description	Discount Amount	Payable Amount	
	Account Number	Account Name	Item Description	Distribution Amount		
2977	Invoice 100-210-727012	01/30/2018	ANNUAL COMPRESSOR SERVICE / FSFD CONTRACTUAL SERVICES ANNUAL COMPRESSOR SERVICE	0.00	1,354.40 1,354.40	
03318	CINTAS CORPORATION	02/07/2018	EFT	0.00	182.74	2003446
4003328116	Invoice 100-430-745000	01/18/2018	2018 OPEN PO / MAT REPLACEMENT / BR JANITORIAL SUPPLIES 2018 OPEN PO / MAT REPLACE	0.00	25.00 25.00	
4003381325	Invoice 100-190-745000	01/18/2018	2018 OPEN PO / (5) BROWN MAT RPLCM JANITORIAL SUPPLIES 2018 OPEN PO / (5) BROWN MA	0.00	53.87 53.87	
4003441221	Invoice 100-430-745000	01/24/2018	2018 OPEN PO / MAT REPLACEMENT / BR JANITORIAL SUPPLIES 2018 OPEN PO / MAT REPLACE	0.00	25.00 25.00	
4003565932	Invoice 100-430-745000	01/31/2018	2018 OPEN PO / MAT REPLACEMENT / BR JANITORIAL SUPPLIES 2018 OPEN PO / MAT REPLACE	0.00	25.00 25.00	
4003618006	Invoice 100-190-745000	02/01/2018	2018 OPEN PO / (5) BROWN MAT RPLCM JANITORIAL SUPPLIES 2018 OPEN PO / (5) BROWN MA	0.00	53.87 53.87	
54445	COPY PRODUCTS INC	02/07/2018	EFT	0.00	600.14	2003447
220356	Invoice 100-190-727004 100-200-727004 100-210-727004 100-240-727004 711-520-727004	01/17/2018	OVERAGE CHARGE (10-15-17 TO 01-14-18 MAINTENANCE AGREEME OVERAGE CHARGE (10-15-17 TO MAINTENANCE AGREEME OVERAGE CHARGE (10-15-17 TO MAINTENANCE AGREEME OVERAGE CHARGE (10-15-17 TO MAINTENANCE AGREEME OVERAGE CHARGE (10-15-17 TO MAINTENANCE AGREEME OVERAGE CHARGE (10-15-17 TO	0.00	600.14 138.55 152.69 152.69 17.66 138.55	
56133	CORE & MAIN	02/07/2018	EFT	0.00	1,263.10	2003448
1270145	Invoice 711-500-743000	01/10/2018	TAPT REPAIR . . . WTP OPERATING SUPPLIES TAPT REPAIR . . . WTP	0.00	1,072.67 1,072.67	
1330944	Invoice 711-500-743000	01/18/2018	BALL VALVE FIPT SHARPE & (2) BRASS NIP OPERATING SUPPLIES BALL VALVE FIPT SHARPE & (2) B	0.00	177.84 177.84	
1340081	Invoice 711-500-743000	01/18/2018	2 X 1-1/4 HEX BUSHING / WTP OPERATING SUPPLIES 2 X 1-1/4 HEX BUSHING / WTP	0.00	12.59 12.59	
64954	CORRECT CARE SOLUTIONS LLC	02/07/2018	EFT	0.00	126.00	2003449
CCS-32748	Invoice 100-200-727000	02/01/2018	INMATE HEALTHCARE SERVICES REPRICIN PRISONER CARE INMATE HEALTHCARE SERVICES	0.00	126.00 126.00	
62567	CRYSTAL LAKE FISHERIES INC	02/07/2018	EFT	0.00	2,047.50	2003450
16935	Invoice 100-400-743000	01/18/2018	(225) RAINBOW TROUT OPERATING SUPPLIES (225) RAINBOW TROUT	0.00	1,023.75 1,023.75	
16971	Invoice 100-400-743000	01/31/2018	(225) RAINBOW TROUT OPERATING SUPPLIES (225) RAINBOW TROUT	0.00	1,023.75 1,023.75	
64947	D & J GLASS	02/07/2018	EFT	0.00	112.19	2003451

My Check Report

Date Range: 02/03/2018 - 02/16/2018

Vendor Number	Vendor Name	Payment Date	Payment Type	Discount Amount	Payment Amount	Number
Payable #	Payable Type	Post Date	Payable Description	Discount Amount	Payable Amount	
	Account Number	Account Name	Item Description	Distribution Amount		
27068	Invoice 100-440-741000	02/01/2018	(12) DS GLASS / JCL&S CONTRACTING @ BUILDING MAINTENANCE (12) DS GLASS / JCL&S CONTRA	0.00	112.19 112.19	
06046	FASTENAL COMPANY	02/07/2018	EFT	0.00	590.58	2003452
KSFOR82054	Invoice 712-540-742000	01/17/2018	(12) BOLT BINS / WWTP EQUIPMENT / VEHICLE M (12) BOLT BINS / WWTP	0.00	38.43 38.43	
KSFOR82065	Invoice 712-540-742000	01/17/2018	6" FIBERGLASS STEPLADDER / WWTP EQUIPMENT / VEHICLE M 6" FIBERGLASS STEPLADDER / W	0.00	72.93 72.93	
KSFOR82135	Invoice 100-420-750000	01/19/2018	HEX NUTS, SHOP TOWELS, CABLE TIES / G MISCELLANEOUS COMM HEX NUTS, SHOP TOWELS, CABL	0.00	10.09 10.09	
KSFOR82314	Invoice 204-300-750000	02/01/2018	FLAT WASHERS & ELEC CONN / STREET DE MISCELLANEOUS COMM FLAT WASHERS & ELEC CONN / S	0.00	28.16 28.16	
KSFOR82320	Invoice 712-550-742000	02/01/2018	4XL HARNESS / WWC EQUIPMENT / VEHICLE M 4XL HARNESS / WWC	0.00	377.10 377.10	
KSFOR82322	Invoice 100-420-750000	02/01/2018	(15) CUTTING WHEELS & (5) FOAM BRUS MISCELLANEOUS COMM (15) CUTTING WHEELS & (5) FO	0.00	13.64 13.64	
KSFOR82323	Invoice 711-500-743000	02/01/2018	WORK GLOVES / WTP OPERATING SUPPLIES WORK GLOVES / WTP	0.00	50.23 50.23	
59926	FOLEY EQUIPMENT COMPANY	02/07/2018	EFT	0.00	148.93	2003453
PS400192702	Invoice 712-550-742000	01/24/2018	SENSOR (LAKE LIFT STATION GENERATOR) EQUIPMENT / VEHICLE M SENSOR (LAKE LIFT STATION GE	0.00	148.93 148.93	
57770	FREEDOM READY MIX INC	02/07/2018	EFT	0.00	434.50	2003454
3989	Invoice 711-510-743000	02/01/2018	4500 PSI,CALCIUM 1%,HOT WATER,FUEL OPERATING SUPPLIES 4500 PSI,CALCIUM 1%,HOT WAT	0.00	434.50 434.50	
07040	GALLS LLC	02/07/2018	EFT	0.00	462.25	2003455
9155278	Invoice 100-210-747000	01/30/2018	(5 PAIR) BATES ULTRA LITE ZIPPER BOOTS UNIFORMS AND CLOTHIN (5 PAIR) BATES ULTRA LITE ZIPPE	0.00	462.25 462.25	
57823	HAWKINS INC	02/07/2018	EFT	0.00	1,588.00	2003456
4215832 RI	Invoice 711-500-752000	01/24/2018	WATER TREATMENT CHEMICALS (WTP) CHEMICALS WATER TREATMENT CHEMICALS	0.00	1,588.00 1,588.00	
08220	HEIDRICKS TRUE VALUE	02/07/2018	EFT	0.00	1,040.27	2003457
A154477	Invoice 711-500-742000	01/17/2018	VARIOUS PIPE FITTINGS / WTP EQUIPMENT / VEHICLE M VARIOUS PIPE FITTINGS / WTP	0.00	86.85 86.85	
A154533	Invoice 711-510-743000	01/17/2018	(3) 28" CURB KEY / WATER DIST OPERATING SUPPLIES (3) 28" CURB KEY / WATER DIST	0.00	32.97 32.97	
A154554	Invoice 711-500-741000	01/17/2018	TOG SWITCH,LB ACCESS FITTING,ADAPTE BUILDING MAINTENANCE TOG SWITCH,LB ACCESS FITTING	0.00	56.22 56.22	
A154571	Invoice	01/17/2018	BLACK RUST ENAMEL / PARKS DEPT	0.00	4.49	

My Check Report

Date Range: 02/03/2018 - 02/16/2018

Vendor Number	Vendor Name	Payment Date	Payment Type	Discount Amount	Payment Amount	Number
	100-400-743000		OPERATING SUPPLIES		4.49	
A154659	Invoice	01/17/2018	HEATER FOR LIFT STATION / WWC	0.00	29.99	
	712-550-742000		EQUIPMENT / VEHICLE M		29.99	
A154826	Invoice	01/17/2018	BUSHINGS, HANDY BOX COVER, CELLPIPE	0.00	16.32	
	711-500-742000		EQUIPMENT / VEHICLE M		16.32	
A154881	Invoice	01/17/2018	PLASTIC TRAY SET & PAINT ROLLER TRAY /	0.00	18.48	
	100-400-743000		OPERATING SUPPLIES		18.48	
A154896	Invoice	01/17/2018	COMB WRENCH & MISC HARDWARE / GO	0.00	11.89	
	100-420-750000		MISCELLANEOUS COMM		11.89	
A154897	Invoice	01/17/2018	BALL VALVE & MALE ADAPTER / STREET D	0.00	4.38	
	204-300-750000		MISCELLANEOUS COMM		4.38	
A154899	Invoice	01/17/2018	PRIMER & PAINT ROLLER TRAY / PARKS DE	0.00	34.97	
	100-400-743000		OPERATING SUPPLIES		34.97	
A154949	Invoice	01/17/2018	MISC HARDWARE / PARKS DEPT	0.00	2.19	
	100-400-743000		OPERATING SUPPLIES		2.19	
A155011	Invoice	01/17/2018	ENTRY LOCKSET / WATER DIST	0.00	15.99	
	711-510-743000		OPERATING SUPPLIES		15.99	
A155033	Invoice	01/17/2018	12" PLUG LED LIGHT FIXTURE / GLF COUR	0.00	32.99	
	100-420-750000		MISCELLANEOUS COMM		32.99	
A155047	Invoice	01/17/2018	WALL PLATE & QUICK CHUCK EXTENSION	0.00	14.48	
	100-210-741000		BUILDING MAINTENANCE		14.48	
A155063	Invoice	01/17/2018	DRY TEXTURE SPRAY & CANVAS DROPCLO	0.00	40.98	
	100-310-741000		BUILDING MAINTENANCE		40.98	
A155282	Invoice	01/19/2018	PRIMER,ICE SCRAPER,PAINT PAIL,BRUSH S	0.00	28.76	
	100-310-741000		BUILDING MAINTENANCE		26.47	
	100-310-750000		MISCELLANEOUS COMM		2.29	
A155294	Invoice	01/19/2018	FLUORESCENT TUBES & GAP & CRACK FO	0.00	110.73	
	204-300-741000		BUILDING MAINTENANCE		110.73	
A155312	Invoice	01/19/2018	SPACKLING / BUNKROOM REMODEL . . . F	0.00	4.29	
	100-210-741000		BUILDING MAINTENANCE		4.29	
A155314	Invoice	01/19/2018	TRIM SCREW & LATEX SEALANT / BUNKR	0.00	17.47	
	100-210-741000		BUILDING MAINTENANCE		17.47	
A155331	Invoice	01/23/2018	PAINT, 9" COMBO COVER, TRAY SET / AIRP	0.00	48.46	
	100-310-741000		BUILDING MAINTENANCE		48.46	
A155357	Invoice	01/24/2018	REDWOOD STAIN / PARKS DEPT	0.00	32.99	
	100-400-743000		OPERATING SUPPLIES		32.99	
A155528	Invoice	01/23/2018	(2) 2" FLEXIBLE COUPLING / WWTP	0.00	12.98	
	712-540-741000		BUILDING MAINTENANCE		12.98	
A155538	Invoice	01/23/2018	VACUUM SWEEPER FILTERS / LAROCHE B	0.00	24.48	
	100-405-745000		JANITORIAL SUPPLIES		24.48	
A155624	Invoice	01/24/2018	PAINTING SUPPLIES / AIRPORT	0.00	15.97	
	100-310-741000		BUILDING MAINTENANCE		15.97	
A155633	Invoice	01/31/2018	3-PC TRAY SET / PARKS DEPT	0.00	5.99	
	100-400-743000		OPERATING SUPPLIES		5.99	
A155659	Invoice	01/26/2018	BRASS NIPPLE & STR ELBOW	0.00	9.98	
	711-500-742000		EQUIPMENT / VEHICLE M		9.98	
B147485	Invoice	01/17/2018	BATTERIES, FLASHLIGHT, EXT CORD, STOR	0.00	146.95	
	711-510-743000		OPERATING SUPPLIES		146.95	
B147526	Credit Memo	01/17/2018	*RETURN* TOG SWITCH&ACCESS FTNG/	0.00	-12.48	
	711-500-741000		BUILDING MAINTENANCE		-12.48	
B147553	Invoice	01/17/2018	3V LITH FLASHLIGHT BATTERY / FSPD	0.00	15.99	
	100-210-750000		MISCELLANEOUS COMM		15.99	

My Check Report

Date Range: 02/03/2018 - 02/16/2018

Vendor Number	Vendor Name	Payment Date	Payment Type	Discount Amount	Payment Amount	Number
B147679	Invoice 711-500-742000	01/17/2018	FEM ADAPTER,MALE ADAPTER,CUTOFF W EQUIPMENT / VEHICLE M FEM ADAPTER,MALE ADAPTER,	0.00	20.91	
B147737	Invoice 711-510-743000	01/17/2018	KNOT CUP BRUSH,UTIL KNIFE,KEY SET,FLA OPERATING SUPPLIES KNOT CUP BRUSH,UTIL KNIFE,K	0.00	70.22	
B147941	Invoice 711-510-743000	01/18/2018	18-PIECE SCREWDRIVER SET / WATER DIS OPERATING SUPPLIES 18-PIECE SCREWDRIVER SET / W	0.00	24.99	
B147980	Invoice 712-540-741000	01/19/2018	SPACKLING, PUTTY KNIFE, SAND PAD / W BUILDING MAINTENANCE SPACKLING, PUTTY KNIFE, SAND	0.00	8.57	
B148139	Invoice 711-510-743000	01/23/2018	"AA" BATTERIES / WATER DIST OPERATING SUPPLIES "AA" BATTERIES / WATER DIST	0.00	12.99	
B148222	Invoice 100-240-750000	02/01/2018	1"X25' POWERLOCK TAPE & 12' TAPE MEA MISCELLANEOUS COMM 1"X25' POWERLOCK TAPE & 12'	0.00	14.78	
B148252	Invoice 711-500-742000	01/26/2018	GALV PLUGS, PTFE SEAL TAPE, RATCH SCR EQUIPMENT / VEHICLE M GALV PLUGS, PTFE SEAL TAPE, R	0.00	22.06	
	Void	02/07/2018	EFT	0.00	0.00	2003458
	Void	02/07/2018	EFT	0.00	0.00	2003459
08260	HENRY KRAFT INC	02/07/2018	EFT	0.00	76.48	2003460
Payable #	Payable Type	Post Date	Payable Description	Discount Amount	Payable Amount	
257005	Invoice 100-200-745000	01/24/2018	FOAM HAND & BODY SHAMPOO / FSPD JANITORIAL SUPPLIES FOAM HAND & BODY SHAMPO	0.00	76.48	
60858	KANSAS GOLF & TURF INC	02/07/2018	EFT	0.00	901.56	2003461
Payable #	Payable Type	Post Date	Payable Description	Discount Amount	Payable Amount	
02-155003	Invoice 100-420-742000	01/12/2018	VARIOUS MOWER PARTS / GOLF COURSE EQUIPMENT / VEHICLE M VARIOUS MOWER PARTS / GOLF	0.00	901.56	
11145	KANSAS MUNICIPAL UTILITIES INC	02/07/2018	EFT	0.00	4,880.00	2003462
Payable #	Payable Type	Post Date	Payable Description	Discount Amount	Payable Amount	
14005	Invoice 711-520-726000 712-555-726000	01/17/2018	2018 KMU MEMBERSHIP DUES DUES AND MEMBERSHIP 2018 KMU MEMBERSHIP DUES DUES AND MEMBERSHIP 2018 KMU MEMBERSHIP DUES	0.00	1,251.00	
14092	Invoice 100-190-726000 711-520-726000 712-555-726000	01/26/2018	2018 OPEN PO / KMU REGIONAL TRAININ DUES AND MEMBERSHIP 2018 OPEN PO / KMU REGIONA DUES AND MEMBERSHIP 2018 OPEN PO / KMU REGIONA DUES AND MEMBERSHIP 2018 OPEN PO / KMU REGIONA	0.00	3,629.00	
11198	KANSAS STATE TREASURER	02/07/2018	EFT	0.00	1,049.68	2003463
Payable #	Payable Type	Post Date	Payable Description	Discount Amount	Payable Amount	
01312018	Invoice 100-000-291002 100-000-291003 100-000-291004 100-000-291005 100-000-291006 100-000-291009	02/01/2018	JAN 2018-PYMT MUNICIPAL COURT STATE MC REINSTATEMENT FEES REINSTATEMENT FEES MC JUDICIAL BRANCH SU JUDICIAL BRANCH SURCHARGE MC JUDICIAL BRANCH ED JUDICIAL BRANCH EDUCATION F MC LAW ENFORCE TRAINI LAW ENFORCEMENT TRNG CEN MC COMM. CORR. SUPER COMMUNITY CORRECTIONS SU MC S.A.F.E. SEAT BELT SAFETY FUND	0.00	1,049.68	
56350	KEY INDUSTRIES INC	02/07/2018	EFT	0.00	276.25	2003464
Payable #	Payable Type	Post Date	Payable Description	Discount Amount	Payable Amount	
254981IN	Invoice 712-540-747000 719-560-747000	01/09/2018	HOODED JCKT & (5) JEANS-A.SWANK, (3) J UNIFORMS AND CLOTHIN (3) JEANS . . . M.EMBRY UNIFORMS AND CLOTHIN HOODED JACKET & (5) JEANS . .	0.00	157.25	
256136IN	Invoice	01/18/2018	(3) JEANS-JON K & (3)T-SHIRTS,(1)SWTSH	0.00	87.50	

My Check Report

Date Range: 02/03/2018 - 02/16/2018

Vendor Number	Vendor Name	Payment Date	Payment Type	Discount Amount	Payment Amount	Number
	100-420-747000		UNIFORMS AND CLOTHIN (3) JEANS-JON K & (3)T-SHIRTS,(87.50	
256378IN	Invoice	01/18/2018	(3 PAIR) JEANS . . . DUSTIN FOWLER/GOLF	0.00	31.50	
	100-420-747000		UNIFORMS AND CLOTHIN (3 PAIR) JEANS . . . DUSTIN FOW		31.50	
61960	KTK ELECTRIC LLC	02/07/2018	EFT	0.00	390.00	2003465
Payable #	Payable Type	Post Date	Payable Description	Discount Amount	Payable Amount	
Account Number	Account Name	Item Description	Distribution Amount			
2273	Invoice	02/01/2018	09-15-17 / TROUBLESHOOT MOTOR & VF	0.00	50.00	
	712-550-727012		CONTRACTUAL SERVICES 09-15-17 / TROUBLESHOOT MO		50.00	
2286	Invoice	02/01/2018	09-19-17/USE OF MEGGER OHM METER-	0.00	50.00	
	712-540-727012		CONTRACTUAL SERVICES 09-19-17/USE OF MEGGER OH		50.00	
2291	Invoice	02/01/2018	09-22-17 / INSPECTION-SOLAR INSTALLATI	0.00	75.00	
	100-240-727012		CONTRACTUAL SERVICES 09-22-17 / INSPECTION-SOLAR I		75.00	
2293	Invoice	02/01/2018	10-06-17 / DISCONNECT ELECTRIC FROM	0.00	90.00	
	712-540-727012		CONTRACTUAL SERVICES 10-06-17 / DISCONNECT ELECTR		90.00	
2295	Invoice	02/01/2018	10-06-17/DEMONSTRATE HOW TO USE A	0.00	75.00	
	711-500-727012		CONTRACTUAL SERVICES 10-06-17/DEMONSTRATE HOW		75.00	
2296	Invoice	02/01/2018	10-06-17/SVC CALL - TROUBLESHOOT LOS	0.00	50.00	
	712-540-727012		CONTRACTUAL SERVICES 10-06-17/SVC CALL - TROUBLES		50.00	
12203	LOCKE SUPPLY CO	02/07/2018	EFT	0.00	882.87	2003466
Payable #	Payable Type	Post Date	Payable Description	Discount Amount	Payable Amount	
Account Number	Account Name	Item Description	Distribution Amount			
33224691-00	Credit Memo	02/01/2018	*CR* RET'D (5) 250W LIGHT BLBS/ORIG IN	0.00	-90.30	
	204-300-743000		OPERATING SUPPLIES *CR* RET'D (5) 250W LIGHT BLB		-90.30	
33224719-01	Invoice	12/29/2017	(16) LIGHT BULBS . . . FSFD STATION #1 BA	0.00	973.17	
	100-210-741000		BUILDING MAINTENANCE (16) LIGHT BULBS . . . FSFD STATI		973.17	
55496	MAYCO ACE HARDWARE	02/07/2018	EFT	0.00	2,340.31	2003467
Payable #	Payable Type	Post Date	Payable Description	Discount Amount	Payable Amount	
Account Number	Account Name	Item Description	Distribution Amount			
38761	Invoice	01/17/2018	LOCKNUTS,TRMNL ADAPTER,PIPE CUTTER	0.00	43.29	
	711-500-741000		BUILDING MAINTENANCE LOCKNUTS,TRMNL ADAPTER,PIP		43.29	
38799	Invoice	01/17/2018	LEXMARK MAGENTA TONER & BLACK STA	0.00	67.37	
	100-150-744000		OFFICE SUPPLIES LEXMARK MAGENTA TONER (D.		61.79	
	711-520-744000		OFFICE SUPPLIES (2) BLACK STAMP REFILL INK (UT		5.58	
38828	Invoice	01/17/2018	TRASH CAN / PARKS DEPT	0.00	17.99	
	100-400-743000		OPERATING SUPPLIES TRASH CAN / PARKS DEPT		17.99	
38853	Invoice	01/17/2018	WORK LIGHT / PARKS DEPT	0.00	33.99	
	100-400-743000		OPERATING SUPPLIES WORK LIGHT / PARKS DEPT		33.99	
39023	Invoice	01/17/2018	(2) BLEACH / WTP	0.00	13.18	
	711-500-745000		JANITORIAL SUPPLIES (2) BLEACH / WTP		13.18	
39046	Invoice	01/17/2018	PRIMER,PAINT,MASKING TAPE,BRUSHES,R	0.00	123.89	
	100-400-743000		OPERATING SUPPLIES PRIMER,PAINT,MASKING TAPE,B		123.89	
39123	Invoice	01/17/2018	VACUUM SWEEPER BAGS / CITY HALL	0.00	25.77	
	100-190-745000		JANITORIAL SUPPLIES VACUUM SWEEPER BAGS / CITY		25.77	
39124	Invoice	01/17/2018	VARIOUS ELECTRICAL FITTINGS / WTP	0.00	23.94	
	711-500-742000		EQUIPMENT / VEHICLE M VARIOUS ELECTRICAL FITTINGS		23.94	
39125	Invoice	01/17/2018	X-MAS LIGHTS&DECORATNS FOR 2019 X-	0.00	303.20	
	100-400-743000		OPERATING SUPPLIES X-MAS LIGHTS&DECORATNS FO		303.20	
39159	Invoice	01/17/2018	LEXMARK CARTRIDGE (M.BRAKER)	0.00	125.99	
	100-130-744000		OFFICE SUPPLIES LEXMARK CARTRIDGE (M.BRAKE		125.99	
39240	Invoice	01/17/2018	SPRAY PAINT / WWC	0.00	3.00	
	712-550-742000		EQUIPMENT / VEHICLE M SPRAY PAINT / WWC		3.00	
39249	Invoice	01/17/2018	(2) COMBO COLOR (R.DUNN)	0.00	85.98	

My Check Report

Date Range: 02/03/2018 - 02/16/2018

Vendor Number	Vendor Name	Payment Date	Payment Type	Discount Amount	Payment Amount	Number
	100-240-744000		OFFICE SUPPLIES (2) COMBO COLOR (R.DUNN)		85.98	
39251	Invoice 100-405-744000	01/17/2018	CYAN,MAGENTA,YELLOW,BLACK PRINTER	0.00	333.96	
39252	Invoice 711-510-744000	01/17/2018	CYAN,YELLOW,MAGENTA,BLACK PRINTER	0.00	354.96	
39275	Invoice 711-510-743000	01/17/2018	SIMPLE GRN,GOOF OFF REMOVER,WIPIN	0.00	24.96	
39278	Invoice 100-310-741000 100-310-742000 711-530-750000	01/17/2018	WIRE THERM, 36" PICK-UP TOOL, ANTI-FR	0.00	60.23	
			BUILDING MAINTENANCE WIRE THERM 18/5 (AIRPORT)		22.25	
			EQUIPMENT / VEHICLE M ANTI-FREEZE (AIRPORT)		17.99	
			MISCELLANEOUS COMM 36" PICK-UP TOOL (LAKE)		19.99	
39287	Invoice 100-400-743000	01/17/2018	TORCH TRIGGER START PROPANE / PARKS	0.00	29.99	
			OPERATING SUPPLIES TORCH TRIGGER START PROPAN		29.99	
39318	Invoice 712-540-742000	01/17/2018	"AA" BATTERIES / WWTP	0.00	19.99	
			EQUIPMENT / VEHICLE M "AA" BATTERIES / WWTP		19.99	
39407	Invoice 100-150-744000	01/18/2018	AVERY 5160 LABELS (D.CLAY)	0.00	27.99	
			OFFICE SUPPLIES AVERY 5160 LABELS (D.CLAY)		27.99	
39478	Invoice 100-190-750000	01/23/2018	(3) 50-LB BAGS ICE MELT / CITY HALL	0.00	47.97	
			MISCELLANEOUS COMM (3) 50-LB BAGS ICE MELT / CITY		47.97	
39588	Invoice 100-440-741000	01/23/2018	LIGHTS,FLSHLIGHT,FELT PADS,BTRYS,SCR	0.00	111.41	
			BUILDING MAINTENANCE LIGHTS,FLSHLIGHT,FELT PADS,BT		111.41	
39601	Invoice 712-540-742000	01/23/2018	(3) HAMMER HANDLES / WWTP	0.00	19.77	
			EQUIPMENT / VEHICLE M (3) HAMMER HANDLES / WWTP		19.77	
39626	Invoice 100-400-743000	01/24/2018	RYL EXT SAT LTX MDHH QT / PARKS DEPT	0.00	14.99	
			OPERATING SUPPLIES RYL EXT SAT LTX MDHH QT / PAR		14.99	
39651	Invoice 712-540-742000	01/19/2018	(2) HAMMER HANDLES / WWTP	0.00	13.18	
			EQUIPMENT / VEHICLE M (2) HAMMER HANDLES / WWTP		13.18	
39876	Invoice 712-540-742000	01/23/2018	WRENCH PIPE,SLIDE LOCK KNIFE,UTLTY K	0.00	53.56	
			EQUIPMENT / VEHICLE M WRENCH PIPE,SLIDE LOCK KNIF		53.56	
39892	Invoice 711-500-742000	01/24/2018	PVC PRIMER, CEMENT RAIN-R-SHINE, 15A	0.00	14.37	
			EQUIPMENT / VEHICLE M PVC PRIMER, CEMENT RAIN-R-S		14.37	
39920	Invoice 711-500-745000	01/24/2018	VACUUM SWEEPER BAGS / WTP	0.00	15.98	
			JANITORIAL SUPPLIES VACUUM SWEEPER BAGS / WTP		15.98	
39929	Invoice 100-150-744000 100-190-745000	01/24/2018	SWIFFER DUSTER REFILLS & POST-ITS	0.00	89.13	
			OFFICE SUPPLIES POSTS-ITS (D.CLAY)		59.16	
			JANITORIAL SUPPLIES SWIFFER DUSTER REFILLS (CITY		29.97	
39930	Invoice 100-240-744000	01/24/2018	BLACK SHARPIES (R.DUNN)	0.00	9.99	
			OFFICE SUPPLIES BLACK SHARPIES (R.DUNN)		9.99	
40061	Invoice 100-230-741000	01/30/2018	PLEATED AIR FLTRS,MOPHEAD,CURV ALU	0.00	57.56	
			BUILDING MAINTENANCE PLEATED AIR FLTRS,MOPHEAD,C		57.56	
40166	Invoice 100-200-744000	01/31/2018	POST-ITS & COPY PAPER / FSPD	0.00	139.16	
			OFFICE SUPPLIES POST-ITS & COPY PAPER / FSPD		139.16	
40170	Invoice 711-510-743000	02/01/2018	9V BATTERY / WATER DIST	0.00	15.99	
			OPERATING SUPPLIES 9V BATTERY / WATER DIST		15.99	
40386	Invoice 100-310-741000 100-310-745000	02/01/2018	SPACKLE & PAPER TOWELS / AIRPORT	0.00	17.58	
			BUILDING MAINTENANCE SPACK1TIME / AIRPORT		7.59	
			JANITORIAL SUPPLIES PAPER TOWELS / AIRPORT		9.99	
	Void	02/07/2018	EFT	0.00	0.00	2003468
	Void	02/07/2018	EFT	0.00	0.00	2003469
63687	NITROPROMO	02/07/2018	EFT	0.00	78.00	2003470

My Check Report

Date Range: 02/03/2018 - 02/16/2018

Vendor Number	Vendor Name	Payment Date	Payment Type	Discount Amount	Payment Amount	Number
Payable #	Payable Type	Post Date	Payable Description	Discount Amount	Payable Amount	
	Account Number	Account Name	Item Description	Distribution Amount		
1003307	Invoice	01/23/2018	(3) ZIP SWEATSHIRTS (DAVE MARTIN)	0.00	78.00	
	100-110-747000		UNIFORMS AND CLOTHIN (3) ZIP SWEATSHIRTS (DAVE MA		78.00	
14190	NORRIS HEATING & AIR CONDITIONING	02/07/2018	EFT	0.00	5,150.50	2003471
81540	Invoice	01/18/2018	REPLACE BLOWER BELTS ON 2 UNITS / FIR	0.00	187.00	
	203-160-741000		BUILDING MAINTENANCE REPLACE BLOWER BELTS ON 2 U		187.00	
81568	Invoice	01/18/2018	BLOWER BELT & 5 MFD CAPACITORS / FIR	0.00	48.50	
	203-160-741000		BUILDING MAINTENANCE BLOWER BELT & 5 MFD CAPACIT		48.50	
81594	Invoice	02/01/2018	FIRST SOURCE BLDG . . . HVAC	0.00	4,915.00	
	203-160-741000		BUILDING MAINTENANCE FIRST SOURCE BLDG . . . HVAC		4,915.00	
60044	PEPSI-COLA BOTTLING COMPANY OF PITTSBUR	02/07/2018	EFT	0.00	236.90	2003472
302455	Invoice	01/31/2018	PRODUCT FOR VENDING MACHINE @ BR	0.00	236.90	
	100-430-749000		CONCESSION SUPPLIES PRODUCT FOR VENDING MACHI		236.90	
56382	PRESTO-X	02/07/2018	EFT	0.00	69.00	2003473
6834819	Invoice	01/31/2018	2018 OPEN PO / GENERAL PEST SERVICE (0.00	69.00	
	100-430-727012		CONTRACTUAL SERVICES 2018 OPEN PO / GENERAL PEST		69.00	
61684	R & R PRODUCTS INC	02/07/2018	EFT	0.00	180.60	2003474
CD2193324	Invoice	01/30/2018	(3) ROLLER OVERHAUL KITS / GOLF COUR	0.00	180.60	
	100-420-742000		EQUIPMENT / VEHICLE M (3) ROLLER OVERHAUL KITS / G		180.60	
19159	SEK MULTI COUNTY HEALTH DEPARTMENT	02/07/2018	EFT	0.00	60.00	2003475
4642	Invoice	01/30/2018	(3) IMMUNIZATIONS FOR EMT CLASS / FS	0.00	60.00	
	100-210-727012		CONTRACTUAL SERVICES (3) IMMUNIZATIONS FOR EMT C		60.00	
19340	SHERWIN WILLIAMS COMPANY	02/07/2018	EFT	0.00	261.32	2003476
9812-7	Invoice	01/24/2018	PAINT, EDGER, PAINT BRUSHES / WWTP	0.00	85.35	
	712-540-741000		BUILDING MAINTENANCE PAINT, EDGER, PAINT BRUSHES /		85.35	
9823-4	Invoice	01/23/2018	PAINT / AIRPORT	0.00	7.79	
	100-310-741000		BUILDING MAINTENANCE PAINT / AIRPORT		7.79	
9829-1	Invoice	01/23/2018	PAINT & FROG TAPE / AIRPORT	0.00	168.18	
	100-310-741000		BUILDING MAINTENANCE PAINT & FROG TAPE / AIRPORT		168.18	
64724	SYSTEMS MANUFACTURING INC	02/07/2018	EFT	0.00	1,442.04	2003477
M2849	Invoice	01/23/2018	FIXED VFD SCALING ISSUES & ADDED NE	0.00	1,442.04	
	711-500-742000		EQUIPMENT / VEHICLE M FIXED VFD SCALING ISSUES & A		1,442.04	
20081	TOUCHTON ELECTRIC INC	02/07/2018	EFT	0.00	50.00	2003478

My Check Report

Date Range: 02/03/2018 - 02/16/2018

Vendor Number	Vendor Name	Payment Date	Payment Type	Discount Amount	Payment Amount	Number
Payable #	Payable Type	Post Date	Payable Description	Discount Amount	Payable Amount	
	Account Number	Account Name	Item Description	Distribution Amount		
26745	Invoice	01/19/2018	2018 OPEN PO / FIRE ALARM & ALARM M	0.00	25.00	
	100-430-727012		CONTRACTUAL SERVICES		25.00	
26775	Invoice	01/19/2018	2018 OPEN PO / FIRE ALARM & ALARM M	0.00	25.00	
	100-430-727012		CONTRACTUAL SERVICES		25.00	
21001	USA BLUE BOOK	02/07/2018	EFT	0.00	61.05	2003479
461649	Invoice	01/17/2018	ELAPSED TIME HR METER / WWC	0.00	61.05	
	712-550-742000		EQUIPMENT / VEHICLE M		61.05	
65106	4 STATE SANITATION LLC	02/09/2018	EFT	0.00	1,900.00	2003483
11104	Invoice	02/06/2018	MONTHLY TRASH SERVICE (JANUARY)	0.00	950.00	
	100-190-727005		TRASH / RECYCLING		60.00	
	100-210-727005		TRASH / RECYCLING		125.00	
	100-310-727005		TRASH / RECYCLING		110.00	
	100-400-727005		TRASH / RECYCLING		110.00	
	100-405-727005		TRASH / RECYCLING		75.00	
	100-410-727005		TRASH / RECYCLING		50.00	
	100-420-727005		TRASH / RECYCLING		50.00	
	100-430-727005		TRASH / RECYCLING		80.00	
	100-440-727005		TRASH / RECYCLING		60.00	
	204-300-727005		TRASH / RECYCLING		40.00	
	711-500-727005		TRASH / RECYCLING		50.00	
	711-510-727005		TRASH / RECYCLING		40.00	
	712-540-727005		TRASH / RECYCLING		50.00	
	712-550-727005		TRASH / RECYCLING		50.00	
11199	Invoice	02/06/2018	MONTHLY TRASH SERVICE (FEBRUARY)	0.00	950.00	
	100-190-727005		TRASH / RECYCLING		60.00	
	100-210-727005		TRASH / RECYCLING		125.00	
	100-310-727005		TRASH / RECYCLING		110.00	
	100-400-727005		TRASH / RECYCLING		110.00	
	100-405-727005		TRASH / RECYCLING		75.00	
	100-410-727005		TRASH / RECYCLING		50.00	
	100-420-727005		TRASH / RECYCLING		50.00	
	100-430-727005		TRASH / RECYCLING		80.00	
	100-440-727005		TRASH / RECYCLING		60.00	
	204-300-727005		TRASH / RECYCLING		40.00	
	711-500-727005		TRASH / RECYCLING		50.00	
	711-510-727005		TRASH / RECYCLING		40.00	
	712-540-727005		TRASH / RECYCLING		50.00	
	712-550-727005		TRASH / RECYCLING		50.00	
61112	ASHCRAFT PEST CONTROL	02/09/2018	EFT	0.00	0.00	2003484
02072018	Invoice	02/07/2018	2018 OPEN PO/PEST SVCS/MNTHLY SPRA	0.00	40.00	
	100-190-727012		CONTRACTUAL SERVICES		40.00	
02072018-1	Invoice	02/07/2018	2018 OPEN PO/PEST SVCS/1604 S NATL &	0.00	65.00	
	100-210-727012		CONTRACTUAL SERVICES		65.00	
62858	BRANDON MALONE PLUMBING	02/09/2018	EFT	0.00	942.41	2003486

My Check Report

Date Range: 02/03/2018 - 02/16/2018

Vendor Number	Vendor Name	Payment Date	Payment Type	Discount Amount	Payment Amount	Number
Payable #	Payable Type	Post Date	Payable Description	Discount Amount	Payable Amount	
	Account Number	Account Name	Item Description	Distribution Amount		
2409	Invoice 100-430-727019	02/06/2018	INSTALL NEW DRINKING FOUNTAIN / BRC NEW GYMNASIUM - SPLI	0.00	771.76 771.76	
4392	Invoice 711-510-727012	02/06/2018	BLEW OUT WATER LINES +PARTS/PROBLE CONTRACTUAL SERVICES	0.00	170.65 170.65	
65317	CHRIS YODER	02/09/2018	EFT	0.00	2,272.00	2003487
02062018	Invoice 309-400-727012	02/06/2018	(142 HOURS) . . . YAT PROJECT @ 1311 S N CONTRACTUAL SERVICES	0.00	2,272.00 2,272.00	
65321	CHRISTOPHER A GARRETT	02/09/2018	EFT	0.00	40.00	2003488
02022018	Invoice 100-200-714000	02/06/2018	WELLNESS INCENTIVE RMBRSMNTS / DES WELLNESS INCENTIVES	0.00	40.00 40.00	
02271	DALE W BOLLINGER	02/09/2018	EFT	0.00	7.38	2003489
02072018	Invoice 100-210-725000	02/08/2018	*MEAL RMBRSMNT* TOOK ENG #3 TO C TRAVEL AND TRAINING	0.00	7.38 7.38	
54263	DAVID B MARTIN	02/09/2018	EFT	0.00	20.00	2003490
02012018	Invoice 100-110-714000	02/06/2018	WELLNESS INCENTIVE RMBRSMNT / DESI WELLNESS INCENTIVES	0.00	20.00 20.00	
56964	DAVID EUGENE BRUNER	02/09/2018	EFT	0.00	43.01	2003491
02022018	Invoice 100-210-725000	02/08/2018	FUEL/TO PICK UP ENGINE #2 FROM CONR TRAVEL AND TRAINING	0.00	43.01 43.01	
64920	DEBORAH NEEDLEMAN	02/09/2018	EFT	0.00	20.00	2003492
02012018	Invoice 100-140-714000	02/06/2018	WELLNESS INCENTIVE RMBRSMNT / DESI WELLNESS INCENTIVES	0.00	20.00 20.00	
04105	DELTA DENTAL PLAN OF KANSAS	02/09/2018	EFT	0.00	76.61	2003493
1001717201802	Invoice 712-540-704000	01/30/2018	FEBRUARY 2018 RETIREE DENTAL INSURA HEALTH INSURANCE	0.00	76.61 76.61	
59013	FORT SCOTT ROTARY CLUB	02/09/2018	EFT	0.00	500.00	2003494
222	Invoice 100-240-726000	02/06/2018	BIKES FOR TYKES / R.DUNN DUES AND MEMBERSHIP	0.00	10.00 10.00	
273	Invoice 100-110-727002	02/06/2018	(10) TACO FEED TICKETS / D.MARTIN ADVERTISING	0.00	60.00 60.00	
277	Invoice 100-130-727002	02/06/2018	(10) TACO FEED TICKETS / J.GARRISON ADVERTISING	0.00	60.00 60.00	
291	Invoice	02/06/2018	BIKES FOR TYKES / J.GARRISON	0.00	10.00	

My Check Report

Date Range: 02/03/2018 - 02/16/2018

Vendor Number	Vendor Name	Payment Date	Payment Type	Discount Amount	Payment Amount	Number
	100-130-726000		DUES AND MEMBERSHIP BIKES FOR TYKES / J.GARRISON		10.00	
292	Invoice	02/06/2018	BIKES FOR TYKES / D.MARTIN	0.00	10.00	
	100-110-726000		DUES AND MEMBERSHIP BIKES FOR TYKES / D.MARTIN		10.00	
295	Invoice	02/06/2018	DUES / JAN-JUN 2018 (R.DUNN)	0.00	70.00	
	100-240-726000		DUES AND MEMBERSHIP DUES / JAN-JUN 2018 (R.DUNN)		70.00	
296	Invoice	02/06/2018	DUES / JUL-DEC 2017 & JAN-JUN 2018 (D.	0.00	140.00	
	100-110-726000		DUES AND MEMBERSHIP DUES / JUL-DEC 2017 & JAN-JU		140.00	
297	Invoice	02/06/2018	DUES / JUL-DEC 2017 & JAN-JUN 2018 (J.	0.00	140.00	
	100-130-726000		DUES AND MEMBERSHIP DUES / JUL-DEC 2017 & JAN-JU		140.00	
08190	HEARTLAND RURAL ELECTRIC COOP	02/09/2018	EFT	0.00	568.84	2003495
Payable #	Payable Type	Post Date	Payable Description	Discount Amount	Payable Amount	
	Account Number		Account Name		Distribution Amount	
161 (02-01-18)	Invoice	02/07/2018	2018 OPEN PO / ELEC SVC-AIRPORT,LAKE,	0.00	568.84	
	100-310-723002		UTILITY - ELECTRIC 2018 OPEN PO / ELEC SVC - AIR		248.21	
	711-530-723002		UTILITY - ELECTRIC 2018 OPEN PO / ELEC SVC - LAK		122.00	
	712-540-723002		UTILITY - ELECTRIC 2018 OPEN PO / ELEC SVC - LIFT		198.63	
63927	JAN ELLEN KELLOGG	02/09/2018	EFT	0.00	80.00	2003496
Payable #	Payable Type	Post Date	Payable Description	Discount Amount	Payable Amount	
	Account Number		Account Name		Distribution Amount	
02062018	Invoice	02/07/2018	2018 OPEN PO / CLEANING SERVICES (CIT	0.00	80.00	
	100-190-727012		CONTRACTUAL SERVICES 2018 OPEN PO / CLEANING SER		80.00	
62769	JASON MCREYNOLDS	02/09/2018	EFT	0.00	28.00	2003497
Payable #	Payable Type	Post Date	Payable Description	Discount Amount	Payable Amount	
	Account Number		Account Name		Distribution Amount	
02022018	Invoice	02/06/2018	**REIMBURSEMENT** CDL ABC DRIVER'	0.00	28.00	
	204-300-727016		LICENSE / PERMIT **REIMBURSEMENT** CDL AB		28.00	
60303	JCL&S CONTRACTING INC	02/09/2018	EFT	0.00	6,747.00	2003498
Payable #	Payable Type	Post Date	Payable Description	Discount Amount	Payable Amount	
	Account Number		Account Name		Distribution Amount	
335	Invoice	02/09/2018	WORK PERFORMED @ MEMORIAL HALL	0.00	6,747.00	
	100-440-741000		BUILDING MAINTENANCE WORK PERFORMED @ MEMORI		6,747.00	
65320	JOHN MALONEY	02/09/2018	EFT	0.00	215.82	2003499
Payable #	Payable Type	Post Date	Payable Description	Discount Amount	Payable Amount	
	Account Number		Account Name		Distribution Amount	
02012018	Invoice	02/06/2018	MILEAGE REIMBURSEMENT (396 MILES) .	0.00	215.82	
	712-550-725000		TRAVEL AND TRAINING MILEAGE REIMBURSEMENT (39		215.82	
53767	JUDYS IRON & METAL INC	02/09/2018	EFT	0.00	516.16	2003500
Payable #	Payable Type	Post Date	Payable Description	Discount Amount	Payable Amount	
	Account Number		Account Name		Distribution Amount	
50608	Invoice	01/17/2018	PVC SCH 40 PIPE / WTP	0.00	37.74	
	711-500-742000		EQUIPMENT / VEHICLE M PVC SCH 40 PIPE / WTP		37.74	
50613	Invoice	01/17/2018	1/8 X 1-1/2 FLAT (PARKS DEPT)	0.00	1.50	
	100-400-743000		OPERATING SUPPLIES 1/8 X 1-1/2 FLAT (PARKS DEPT)		1.50	
50651	Invoice	01/17/2018	16GA SHEET .060 TEAL GREEN & 1X1X1/8	0.00	12.68	
	711-500-742000		EQUIPMENT / VEHICLE M 16GA SHEET .060 TEAL GREEN &		12.68	
50662	Invoice	01/17/2018	PVC MPT ADAPTERS & PVC BUSHINGS /	0.00	7.52	
	711-500-742000		EQUIPMENT / VEHICLE M PVC MPT ADAPTERS & PVC BUS		7.52	
50663	Credit Memo	01/17/2018	**CREDIT** RETURNED PVC SCH 40 PIP	0.00	-9.18	
	711-500-742000		EQUIPMENT / VEHICLE M **CREDIT** RETURNED PVC S		-9.18	
50729	Invoice	01/19/2018	2 X 2 X 1/8 ANGLE (UNIT 256)	0.00	3.11	
	204-300-742000		EQUIPMENT / VEHICLE M 2 X 2 X 1/8 ANGLE (UNIT 256)		3.11	

My Check Report

Date Range: 02/03/2018 - 02/16/2018

Vendor Number	Vendor Name	Payment Date	Payment Type	Discount Amount	Payment Amount	Number
50730	Invoice 712-550-742000	01/23/2018	(10) 1/4 X 1-1/2 FLAT . . . WWC EQUIPMENT / VEHICLE M (10) 1/4 X 1-1/2 FLAT . . . WWC	0.00	7.10	
50756	Invoice 712-540-741000	01/23/2018	1/2" BRASS UNION & BRASS NIPPLE / W BUILDING MAINTENANCE 1/2" BRASS UNION & BRASS NIP	0.00	12.13	
50762	Invoice 711-510-743000	01/23/2018	(4) 12 GA HOT ROLL SHEETS / WATER DIS OPERATING SUPPLIES (4) 12 GA HOT ROLL SHEETS /	0.00	15.00	
50785	Invoice 711-510-743000	02/07/2018	18" HANCOR PIPE / WATER DIST OPERATING SUPPLIES 18" HANCOR PIPE / WATER DIST	0.00	358.87	
50821	Invoice 711-510-743000	01/30/2018	PVC PIPE,TEES,ADAPTERS,VALVES,COUPLI OPERATING SUPPLIES PVC PIPE,TEES,ADAPTERS,VALVE	0.00	68.39	
50827	Invoice 100-440-741000	01/31/2018	1 X 1 X 1/8 ANGLE . . . MEMORIAL HALL BUILDING MAINTENANCE 1 X 1 X 1/8 ANGLE . . . MEMORI	0.00	1.30	

11340	KIRKLAND WELDING SUPPLIES INC	02/09/2018	EFT	0.00	352.75	2003501
Payable #	Payable Type	Post Date	Payable Description	Discount Amount	Payable Amount	
	Account Number		Account Name	Item Description	Distribution Amount	
918798	Invoice 711-500-742000	01/17/2018	(4) HINGE/WELD-ON FLAT 2" / WTP EQUIPMENT / VEHICLE M (4) HINGE/WELD-ON FLAT 2" /	0.00	6.00	
918804	Invoice 711-510-742000	01/19/2018	EVOLUTION 14" CUTTING STEEL BLADE / EQUIPMENT / VEHICLE M EVOLUTION 14" CUTTING STEEL	0.00	124.98	
918926	Invoice 100-400-743000	01/17/2018	CUTOFFS & SAFE GLASS/BIFOCAL (PARKS OPERATING SUPPLIES CUTOFFS & SAFE GLASS/BIFOCA	0.00	17.46	
919077	Invoice 711-510-743000	01/18/2018	L11 035 SOLID ER70S-6 & (3) GRIND WHE OPERATING SUPPLIES L11 035 SOLID ER70S-6 & (3) GR	0.00	36.97	
919412	Invoice 100-400-743000	02/07/2018	ARGON,FLAP DISCS,CUTOFFS,GLOVE/DRI OPERATING SUPPLIES ARGON,FLAP DISCS,CUTOFFS,GL	0.00	79.34	
919530	Invoice 204-300-727004	02/06/2018	JANUARY / MONTHLY CYLINDER RENTAL MAINTENANCE AGREEME JANUARY / MONTHLY CYLINDER	0.00	88.00	

65201	LARRY GAZAWAY	02/09/2018	EFT	0.00	245.25	2003502
Payable #	Payable Type	Post Date	Payable Description	Discount Amount	Payable Amount	
	Account Number		Account Name	Item Description	Distribution Amount	
02072018	Invoice 208-165-725000	02/09/2018	MILEAGE RMBRSMNT/01-31 KC-CPM & 0 TRAVEL AND TRAINING MILEAGE RMBRSMNT/01-31 KC-	0.00	245.25	

12210	LOCKWOOD MOTOR SUPPLY INC	02/09/2018	EFT	0.00	1,382.44	2003503
Payable #	Payable Type	Post Date	Payable Description	Discount Amount	Payable Amount	
	Account Number		Account Name	Item Description	Distribution Amount	
5201-262882	Invoice 100-420-742000	01/17/2018	(2) HYDRAULIC / GOLF COURSE EQUIPMENT / VEHICLE M (2) HYDRAULIC / GOLF COURSE	0.00	22.54	
5201-262973	Invoice 100-200-742000	01/17/2018	(6) WASHER FLUID / FSPD EQUIPMENT / VEHICLE M (6) WASHER FLUID / FSPD	0.00	21.00	
5201-263053	Invoice 712-550-742000	01/17/2018	FUEL FILTER (UNIT 980) EQUIPMENT / VEHICLE M FUEL FILTER (UNIT 980)	0.00	10.38	
5201-263057	Invoice 711-510-742000	01/17/2018	HYDRAULIC FLUID & DOOR HINGE PIN / EQUIPMENT / VEHICLE M HYDRAULIC FLUID & DOOR HIN	0.00	32.66	
5201-263058	Invoice 712-550-742000	01/17/2018	FUEL FILTER (UNIT 980) EQUIPMENT / VEHICLE M FUEL FILTER (UNIT 980)	0.00	14.16	
5201-263133	Invoice 711-510-743000	01/17/2018	COMBO WRENCH & 15/16 RATCH WRENC OPERATING SUPPLIES COMBO WRENCH & 15/16 RATC	0.00	29.98	
5201-263188	Invoice 100-210-743000	01/17/2018	(5) 2-CYCLE OIL / FSFD OPERATING SUPPLIES (5) 2-CYCLE OIL / FSFD	0.00	8.50	
5201-263268	Invoice 204-300-742000	01/17/2018	AIR FILTER (UNIT 220) EQUIPMENT / VEHICLE M AIR FILTER (UNIT 220)	0.00	36.95	
5201-263269	Invoice	01/17/2018	AIR FILTER, GEAR OIL, (3) FUEL FILTERS/G	0.00	60.12	

My Check Report

Date Range: 02/03/2018 - 02/16/2018

Vendor Number	Vendor Name	Payment Date	Payment Type	Discount Amount	Payment Amount	Number
	100-420-742000		EQUIPMENT / VEHICLE M AIR FILTER, GEAR OIL, (3) FUEL F		60.12	
5201-263271	Invoice	01/17/2018	ENGINE BARRING TOOL (UNIT 282)	0.00	61.95	
	204-300-742000		EQUIPMENT / VEHICLE M ENGINE BARRING TOOL (UNIT 2		61.95	
5201-263290	Invoice	01/17/2018	16MJ-PLUG (UNIT 282)	0.00	5.81	
	204-300-742000		EQUIPMENT / VEHICLE M 16MJ-PLUG (UNIT 282)		5.81	
5201-263297	Invoice	01/17/2018	OIL FILTER, HYDRAULIC, FUEL FILTER / GO	0.00	30.92	
	100-420-742000		EQUIPMENT / VEHICLE M OIL FILTER, HYDRAULIC, FUEL FIL		30.92	
5201-263307	Invoice	01/17/2018	HARMONIC BALANCE & HAND-HELD WOR	0.00	98.51	
	204-300-750000		MISCELLANEOUS COMM HARMONIC BALANCE & HAND-		98.51	
5201-263308	Invoice	01/17/2018	HEATER HOSE CONNECTOR & ANTI-FREEZ	0.00	16.18	
	711-510-742000		EQUIPMENT / VEHICLE M HEATER HOSE CONNECTOR & A		16.18	
5201-263325	Invoice	01/17/2018	(4) BOLTS / UNIT 282	0.00	9.08	
	204-300-742000		EQUIPMENT / VEHICLE M (4) BOLTS / UNIT 282		9.08	
5201-263356	Invoice	01/17/2018	DEX III, BRAKE CLNR, HND-HELD WORK LM	0.00	187.55	
	204-300-742000		EQUIPMENT / VEHICLE M DEX III, BRAKE CLEANER, TRANS		93.03	
	204-300-750000		MISCELLANEOUS COMM HAND-HELD WORK LAMP / STR		94.52	
5201-263475	Invoice	01/17/2018	BRAKE LINE (UNIT 522)	0.00	10.09	
	204-300-742000		EQUIPMENT / VEHICLE M BRAKE LINE (UNIT 522)		10.09	
5201-263527	Invoice	01/17/2018	(7) OIL & OIL FILTER / WATER DIST	0.00	20.20	
	711-510-742000		EQUIPMENT / VEHICLE M (7) OIL & OIL FILTER / WATER DI		20.20	
5201-263531	Invoice	01/17/2018	STONE GLAZE BREAKER / GOLF COURSE	0.00	21.99	
	100-420-750000		MISCELLANEOUS COMM STONE GLAZE BREAKER / GOLF		21.99	
5201-263579	Invoice	01/17/2018	NORSEMAN & CARBON TAP / GOLF COUR	0.00	6.23	
	100-420-750000		MISCELLANEOUS COMM NORSEMAN & CARBON TAP / G		6.23	
5201-263655	Invoice	01/23/2018	(2) WINDSHIELD WIPERS / WWTP	0.00	17.98	
	712-540-742000		EQUIPMENT / VEHICLE M (2) WINDSHIELD WIPERS / WWT		17.98	
5201-263876	Invoice	01/18/2018	(2) OIL SEALS / GOLF COURSE TORO MOW	0.00	15.80	
	100-420-742000		EQUIPMENT / VEHICLE M (2) OIL SEALS / GOLF COURSE T		15.80	
5201-263880	Invoice	01/18/2018	(2) OIL SEALS / GOLF COURSE MOWER	0.00	12.90	
	100-420-742000		EQUIPMENT / VEHICLE M (2) OIL SEALS / GOLF COURSE M		12.90	
5201-263885	Invoice	01/19/2018	COMBINATION SWITCH & ELECT-MECH FL	0.00	184.59	
	204-300-742000		EQUIPMENT / VEHICLE M COMBINATION SWITCH & ELECT		184.59	
5201-263891	Invoice	01/19/2018	FUEL FILTER (AIRPORT FUEL TRUCK)	0.00	14.27	
	100-310-742000		EQUIPMENT / VEHICLE M FUEL FILTER (AIRPORT FUEL TRU		14.27	
5201-263913	Invoice	01/23/2018	TRAILER CONNECTOR (UNIT 345)	0.00	8.72	
	204-300-742000		EQUIPMENT / VEHICLE M TRAILER CONNECTOR (UNIT 345		8.72	
5201-263986	Invoice	01/23/2018	AIR FILTER & (10) TUBE GREASE / GOLF C	0.00	54.49	
	100-420-742000		EQUIPMENT / VEHICLE M AIR FILTER & (10) TUBE GREASE		54.49	
5201-264051	Invoice	01/23/2018	OIL & XTREME BLUE / WATER DIST	0.00	30.84	
	711-510-742000		EQUIPMENT / VEHICLE M OIL & XTREME BLUE / WATER DI		30.84	
5201-264092	Invoice	01/23/2018	RIGHT REAR LAMP / WATER DIST	0.00	82.80	
	711-510-742000		EQUIPMENT / VEHICLE M RIGHT REAR LAMP / WATER DIS		82.80	
5201-264140	Invoice	01/23/2018	SYDR FITTING (UNIT 255)	0.00	9.75	
	204-300-742000		EQUIPMENT / VEHICLE M SYDR FITTING (UNIT 255)		9.75	
5201-264141	Credit Memo	01/23/2018	**CR** RET'D SYDR FITTING (ORIG INV #	0.00	-9.75	
	204-300-742000		EQUIPMENT / VEHICLE M **CR** RET'D SYDR FITTING (O		-9.75	
5201-264158	Invoice	01/23/2018	8MP-6FPS (UNIT 255)	0.00	2.06	
	204-300-742000		EQUIPMENT / VEHICLE M 8MP-6FPS (UNIT 255)		2.06	
5201-264178	Invoice	01/23/2018	(2) OIL FILTERS / GOLF COURSE UTILITY VE	0.00	4.20	
	100-420-742000		EQUIPMENT / VEHICLE M (2) OIL FILTERS / GOLF COURSE		4.20	
5201-264183	Invoice	01/24/2018	BOSH OIL PSI / WWC	0.00	34.47	
	712-550-742000		EQUIPMENT / VEHICLE M BOSH OIL PSI / WWC		34.47	

My Check Report

Date Range: 02/03/2018 - 02/16/2018

Vendor Number	Vendor Name	Payment Date	Payment Type	Discount Amount	Payment Amount	Number
5201-264215	Invoice 204-300-742000	01/23/2018	(2) WIPER BLADES / STREET DEPT EQUIPMENT / VEHICLE M (2) WIPER BLADES / STREET DEP	0.00	43.48	
5201-264220	Invoice 204-300-742000	01/25/2018	(3) PUSH-TYPE RETAINER (UNIT 227) EQUIPMENT / VEHICLE M (3) PUSH-TYPE RETAINER (UNIT	0.00	0.75	
5201-264295	Invoice 100-400-742000	01/31/2018	HYDRAULIC HOSE REPAIR PART / PARKS D EQUIPMENT / VEHICLE M HYDRAULIC HOSE REPAIR PART /	0.00	10.85	
5201-264312	Invoice 100-200-750000	01/25/2018	ANGLED DISCONNECT MISCELLANEOUS COMM ANGLED DISCONNECT	0.00	19.39	
5201-264315	Invoice 204-300-750000	01/25/2018	2-1/4 EXHAUST CLAMP MISCELLANEOUS COMM 2-1/4 EXHAUST CLAMP	0.00	2.40	
5201-264328	Invoice 100-200-742000	01/25/2018	STEEL CONNECTOR CLIP (UNIT 135) EQUIPMENT / VEHICLE M STEEL CONNECTOR CLIP (UNIT 1	0.00	9.85	
5201-264338	Invoice 204-300-750000	01/25/2018	(3) HD CLAMPS MISCELLANEOUS COMM (3) HD CLAMPS	0.00	7.20	
5201-264375	Invoice 100-420-742000	01/30/2018	WIRE TERMINALS & BATTERY CABLE / GO EQUIPMENT / VEHICLE M WIRE TERMINALS & BATTERY CA	0.00	6.08	
5201-264394	Invoice 204-300-750000	01/30/2018	(12) BRAKE CLEANER / STREET DEPT MISCELLANEOUS COMM (12) BRAKE CLEANER / STREET D	0.00	25.74	
5201-264619	Invoice 100-210-743000	01/30/2018	SPRAY LUBE A / FSFD OPERATING SUPPLIES SPRAY LUBE A / FSFD	0.00	11.86	
5201-264652	Invoice 204-300-742000	02/07/2018	(2) FUEL FILTERS (UNIT 282) EQUIPMENT / VEHICLE M (2) FUEL FILTERS (UNIT 282)	0.00	29.83	
5201-264706	Invoice 204-300-742000	02/07/2018	HYDRAULIC OIL / STREET DEPT EQUIPMENT / VEHICLE M HYDRAULIC OIL / STREET DEPT	0.00	28.95	
5201-264764	Invoice 204-300-742000	02/07/2018	LOC 5G SG BTL & DRY GRAPHITE LUBE (U EQUIPMENT / VEHICLE M LOC 5G SG BTL & DRY GRAPHITE	0.00	18.14	
	Void	02/09/2018	EFT	0.00	0.00	2003504
	Void	02/09/2018	EFT	0.00	0.00	2003505
	Void	02/09/2018	EFT	0.00	0.00	2003506
64916	LYNETTE S WESTHOFF	02/09/2018	EFT	0.00	216.00	2003507
Payable #	Payable Type	Post Date	Payable Description	Discount Amount	Payable Amount	
02062018	Invoice 100-430-727012	02/08/2018	FITNESS CLASSES . . 18 PARTICIPANTS (PY CONTRACTUAL SERVICES FITNESS CLASSES . . 18 PARTICIP	0.00	216.00	
54250	R & R EQUIPMENT	02/09/2018	EFT	0.00	421.07	2003508
Payable #	Payable Type	Post Date	Payable Description	Discount Amount	Payable Amount	
01-49077	Invoice 100-310-742000	01/23/2018	10' GRADER BLADE (PLUS FRT) / AIRPORT EQUIPMENT / VEHICLE M 10' GRADER BLADE (PLUS FRT) /	0.00	421.07	
60247	SAKER TOWING LLC	02/09/2018	EFT	0.00	129.00	2003509
Payable #	Payable Type	Post Date	Payable Description	Discount Amount	Payable Amount	
12389	Invoice 100-200-727012	02/08/2018	WHEEL LIFT . . 2002 CHEVY 1500 (LAKE PA CONTRACTUAL SERVICES WHEEL LIFT . . 2002 CHEVY 150	0.00	129.00	
65246	SARA ROOD	02/09/2018	EFT	0.00	100.00	2003510
Payable #	Payable Type	Post Date	Payable Description	Discount Amount	Payable Amount	
02022018	Invoice 100-200-727012	02/07/2018	FSPD / WEEKLY CLEANING SERVICE CONTRACTUAL SERVICES FSPD / WEEKLY CLEANING SERVI	0.00	100.00	
60607	SCHULTE SUPPLY INC	02/09/2018	EFT	0.00	609.57	2003511

My Check Report

Date Range: 02/03/2018 - 02/16/2018

Vendor Number	Vendor Name	Payment Date	Payment Type	Discount Amount	Payment Amount	Number
Payable #	Payable Type	Post Date	Payable Description	Discount Amount	Payable Amount	
	Account Number	Account Name	Item Description	Distribution Amount		
51131254.005	Invoice	02/06/2018	(13) 1" JONES ANGLE VALVE LOCK CAPS / OPERATING SUPPLIES	0.00	609.57	
	711-510-743000		(13) 1" JONES ANGLE VALVE LO		609.57	
57142	VAN PATTEN HEATING	02/09/2018	EFT	0.00	79.00	2003512
01302018	Invoice	02/08/2018	RESET HIGH TEMP TRIP ON ICE MAKER @ EQUIPMENT / VEHICLE M	0.00	79.00	
	100-420-742000		RESET HIGH TEMP TRIP ON ICE		79.00	
54822	ZINGRE AND ASSOCIATES PA	02/09/2018	EFT	0.00	2,055.00	2003513
3232	Invoice	02/08/2018	0501.13 CODE REVIEW SERVICES	0.00	165.00	
	203-160-734000		GRANTS		165.00	
3244	Invoice	02/08/2018	0501.13 CODE REVIEW SERVICES	0.00	1,890.00	
	203-160-734000		GRANTS		1,890.00	
63927	JAN ELLEN KELLOGG	02/16/2018	EFT	0.00	80.00	2003550
02132018	Invoice	02/15/2018	2018 OPEN PO / CLEANING SERVICES (CIT CONTRACTUAL SERVICES	0.00	80.00	
	100-190-727012		2018 OPEN PO / CLEANING SER		80.00	
65246	SARA ROOD	02/16/2018	EFT	0.00	100.00	2003551
02092018	Invoice	02/15/2018	FSPD / WEEKLY CLEANING SERVICE	0.00	100.00	
	100-200-727012		CONTRACTUAL SERVICES		100.00	
64636	GREAT WEST FINANCIAL (KPER547)	02/09/2018	Bank Draft	0.00	50.00	DFT0002139
INV0003146	Invoice	02/09/2018	Deferred Comp - KPER547	0.00	50.00	
	100-000-202000		PAYROLL LIABILITY CLEARI		50.00	
63887	IRS	02/09/2018	Bank Draft	0.00	24,757.38	DFT0002140
INV0003178	Invoice	02/09/2018	Social Security Tax	0.00	10,694.76	
	100-000-202000		PAYROLL LIABILITY CLEARI		5,199.60	
	204-000-202000		PAYROLL LIABILITY CLEARI		1,014.42	
	208-000-202000		PAYROLL LIABILITY CLEARI		318.06	
	711-000-202000		PAYROLL LIABILITY CLEARI		2,393.56	
	712-000-202000		PAYROLL LIABILITY CLEARI		1,665.28	
	719-000-202000		PAYROLL LIABILITY CLEARI		103.84	
INV0003180	Invoice	02/09/2018	Medicare Tax	0.00	4,045.02	
	100-000-202000		PAYROLL LIABILITY CLEARI		2,759.88	
	204-000-202000		PAYROLL LIABILITY CLEARI		237.26	
	208-000-202000		PAYROLL LIABILITY CLEARI		74.40	
	711-000-202000		PAYROLL LIABILITY CLEARI		559.78	
	712-000-202000		PAYROLL LIABILITY CLEARI		389.42	
	719-000-202000		PAYROLL LIABILITY CLEARI		24.28	
INV0003181	Invoice	02/09/2018	Federal Tax	0.00	10,017.60	
	100-000-202000		PAYROLL LIABILITY CLEARI		7,059.53	
	204-000-202000		PAYROLL LIABILITY CLEARI		611.12	
	208-000-202000		PAYROLL LIABILITY CLEARI		157.10	
	711-000-202000		PAYROLL LIABILITY CLEARI		1,241.80	

My Check Report

Date Range: 02/03/2018 - 02/16/2018

Vendor Number	Vendor Name	Payment Date	Payment Type	Discount Amount	Payment Amount	Number
	712-000-202000	PAYROLL LIABILITY CLEARI	Federal Tax		948.05	
46002	KANSAS DEPARTMENT OF REVENUE	02/09/2018	Bank Draft	0.00	4,947.96	DFT0002141
Payable #	Payable Type	Post Date	Payable Description	Discount Amount	Payable Amount	
INV0003179	Invoice	02/09/2018	State Withholding Tax	0.00	4,947.96	
	100-000-202000		PAYROLL LIABILITY CLEARI		3,456.32	
	204-000-202000		PAYROLL LIABILITY CLEARI		269.54	
	208-000-202000		PAYROLL LIABILITY CLEARI		72.99	
	711-000-202000		PAYROLL LIABILITY CLEARI		637.65	
	712-000-202000		PAYROLL LIABILITY CLEARI		490.50	
	719-000-202000		PAYROLL LIABILITY CLEARI		20.96	
11149	KANSAS PAYMENT CENTER	02/09/2018	Bank Draft	0.00	247.84	DFT0002142
Payable #	Payable Type	Post Date	Payable Description	Discount Amount	Payable Amount	
INV0003175	Invoice	02/09/2018	BB04DM000048	0.00	109.38	
	100-000-202000		PAYROLL LIABILITY CLEARI		109.38	
INV0003176	Invoice	02/09/2018	BB14DM000108	0.00	138.46	
	719-000-202000		PAYROLL LIABILITY CLEARI		138.46	
45989	KP&F	02/09/2018	Bank Draft	0.00	15,002.08	DFT0002143
Payable #	Payable Type	Post Date	Payable Description	Discount Amount	Payable Amount	
INV0003164	Invoice	02/09/2018	KP&F	0.00	15,002.08	
	100-000-202000		PAYROLL LIABILITY CLEARI		15,002.08	
45990	KPERS	02/09/2018	Bank Draft	0.00	13,501.80	DFT0002144
Payable #	Payable Type	Post Date	Payable Description	Discount Amount	Payable Amount	
INV0003165	Invoice	02/09/2018	KPERS Insurance	0.00	877.32	
	100-000-202000		PAYROLL LIABILITY CLEARI		416.97	
	204-000-202000		PAYROLL LIABILITY CLEARI		76.23	
	208-000-202000		PAYROLL LIABILITY CLEARI		26.75	
	711-000-202000		PAYROLL LIABILITY CLEARI		208.23	
	712-000-202000		PAYROLL LIABILITY CLEARI		140.54	
	719-000-202000		PAYROLL LIABILITY CLEARI		8.60	
INV0003166	Invoice	02/09/2018	KPERS	0.00	4,616.97	
	100-000-202000		PAYROLL LIABILITY CLEARI		2,360.55	
	204-000-202000		PAYROLL LIABILITY CLEARI		538.36	
	711-000-202000		PAYROLL LIABILITY CLEARI		975.57	
	712-000-202000		PAYROLL LIABILITY CLEARI		742.49	
INV0003167	Invoice	02/09/2018	KPERS	0.00	2,744.81	
	100-000-202000		PAYROLL LIABILITY CLEARI		1,309.29	
	204-000-202000		PAYROLL LIABILITY CLEARI		145.51	
	711-000-202000		PAYROLL LIABILITY CLEARI		1,011.30	
	712-000-202000		PAYROLL LIABILITY CLEARI		278.71	
INV0003168	Invoice	02/09/2018	KPERS	0.00	5,262.70	
	100-000-202000		PAYROLL LIABILITY CLEARI		2,330.44	
	204-000-202000		PAYROLL LIABILITY CLEARI		412.71	
	208-000-202000		PAYROLL LIABILITY CLEARI		384.93	
	711-000-202000		PAYROLL LIABILITY CLEARI		1,009.43	
	712-000-202000		PAYROLL LIABILITY CLEARI		1,001.44	
	719-000-202000		PAYROLL LIABILITY CLEARI		123.75	
61765	SECURITY BENEFIT (wire)	02/09/2018	Bank Draft	0.00	425.32	DFT0002145

My Check Report

Date Range: 02/03/2018 - 02/16/2018

Vendor Number	Vendor Name	Payment Date	Payment Type	Discount Amount	Payment Amount	Number
Payable #	Payable Type	Post Date	Payable Description	Discount Amount	Payable Amount	
	Account Number	Account Name	Item Description	Distribution Amount		
INV0003145	Invoice	02/09/2018	Deferred Comp - 0613086	0.00	349.42	
	100-000-202000		PAYROLL LIABILITY CLEARI		132.06	
	711-000-202000		PAYROLL LIABILITY CLEARI		107.06	
	712-000-202000		PAYROLL LIABILITY CLEARI		110.30	
INV0003147	Invoice	02/09/2018		0.00	75.90	
	100-000-202000		PAYROLL LIABILITY CLEARI		25.05	
	711-000-202000		PAYROLL LIABILITY CLEARI		25.80	
	712-000-202000		PAYROLL LIABILITY CLEARI		25.05	
65245	SELECT ACCOUNT	02/09/2018	Bank Draft	0.00	1,030.16	DFT0002146
INV0003162	Invoice	02/09/2018	HSA	0.00	182.50	
	100-000-202000		PAYROLL LIABILITY CLEARI		182.50	
INV0003163	Invoice	02/09/2018	HSA	0.00	847.66	
	100-000-202000		PAYROLL LIABILITY CLEARI		303.66	
	204-000-202000		PAYROLL LIABILITY CLEARI		59.00	
	711-000-202000		PAYROLL LIABILITY CLEARI		264.75	
	712-000-202000		PAYROLL LIABILITY CLEARI		190.75	
	719-000-202000		PAYROLL LIABILITY CLEARI		29.50	
64315	TASC	02/09/2018	Bank Draft	0.00	1,381.35	DFT0002147
INV0003150	Invoice	02/09/2018	FSA Dependent	0.00	208.33	
	100-000-202000		PAYROLL LIABILITY CLEARI		208.33	
INV0003151	Invoice	02/09/2018	FSA Medical	0.00	240.42	
	100-000-202000		PAYROLL LIABILITY CLEARI		240.42	
INV0003152	Invoice	02/09/2018	FSA Medical	0.00	827.60	
	100-000-202000		PAYROLL LIABILITY CLEARI		335.94	
	204-000-202000		PAYROLL LIABILITY CLEARI		96.90	
	711-000-202000		PAYROLL LIABILITY CLEARI		217.58	
	712-000-202000		PAYROLL LIABILITY CLEARI		177.18	
INV0003153	Invoice	02/09/2018	FSA NESP	0.00	105.00	
	711-000-202000		PAYROLL LIABILITY CLEARI		105.00	
60730	FORT SCOTT GOLF COURSE INC	02/09/2018	Bank Draft	0.00	4,011.83	DFT0002148
02092018	Invoice	02/09/2018	2018 OPEN PO / MNTHLY PYMT TO PURC	0.00	4,011.83	
	600-600-803001		LEASE PURCHASE - GOLF		4,011.83	
64794	PURPLE WAVE INC	02/13/2018	Bank Draft	0.00	24,750.00	DFT0002149

My Check Report

Date Range: 02/03/2018 - 02/16/2018

Vendor Number	Vendor Name	Payment Date	Payment Type	Discount Amount	Payment Amount	Number
Payable #	Payable Type	Post Date	Payable Description	Discount Amount	Payable Amount	
Account Number	Account Name	Item Description	Distribution Amount			
02092018	Invoice	02/13/2018	2009 INTERNATIONAL DURASTAR 4300 B	0.00	24,750.00	
204-300-764000	MACHINERY AND EQUIP	2009 INTERNATIONAL DURASTA			24,750.00	

Bank Code MM Summary

Payment Type	Payable Count	Payment Count	Discount	Payment
Regular Checks	127	41	0.00	180,490.85
Manual Checks	0	0	0.00	0.00
Voided Checks	0	5	0.00	0.00
Bank Drafts	22	11	0.00	90,105.72
EFT's	229	70	0.00	49,536.25
	378	127	0.00	320,132.82

All Bank Codes Check Summary

Payment Type	Payable Count	Payment Count	Discount	Payment
Regular Checks	127	41	0.00	180,490.85
Manual Checks	0	0	0.00	0.00
Voided Checks	0	5	0.00	0.00
Bank Drafts	22	11	0.00	90,105.72
EFT's	229	70	0.00	49,536.25
	378	127	0.00	320,132.82

Fund Summary

Fund	Name	Period	Amount
999	POOLED CASH	2/2018	320,132.82
			<u>320,132.82</u>

AGREEMENT

This Agreement, made this 20th day of **February, 2018** between the City of Fort Scott [hereinafter referred to as "City"] and Archer-Daniels-Midland Company [hereinafter referred to as "ADM"];

WHEREAS, ADM is operating a biodiesel plant and is purchasing wastewater from the City for utilization at its plant; and ADM is also delivering wastewater to the City Wastewater Treatment Plant for treatment under the City NPDES Permit

WHEREAS, the City desires to sell wastewater to ADM; and also agrees to receive wastewater for treatment

WHEREFORE, the parties agree as follows:

1. The City agrees to sell to ADM treated wastewater effluent meeting the specifications attached hereto as Exhibit A, from its wastewater plant for One Dollar and Seventy Cents [\$1.70] per One Hundred Cubic Feet (100 c.f.), or (748 gallons), with the quantity to be measured at the City Wastewater Plant but the minimum payment made to the City by ADM will be \$50,000 per annum to be paid in minimum monthly installments of Four Thousand One Hundred Sixty-Six Dollars and Sixty-Seven Cents [\$4,166.67).

2. The City agrees to receive for treatment, from ADM, wastewater delivered by ADM, into the City Lagoon system, for Zero Dollars and Five Cents [\$0.05] per Gallon. The wastewater delivered to City by ADM must meet the following specifications: pH shall be between 6 and 9, BOD or COD shall not exceed 1500 mg/L, TSS shall not exceed 350 mg/L. If it becomes apparent over time that these aforementioned specifications are beyond the ability of City Lagoons to treat, and NPDES limits are violated as a result of receiving this wastewater from ADM, the City will give ADM 30 days written notice that volume of waste water received must be reduced and volume capped a specific volume set by Wastewater Treatment Plant Supervisor until the City is able to meet all NPDES limits.

3. The period of this agreement shall be five (5) years from the date first above written. It may be extended for an additional five (5) years upon written notification from ADM to the City at least one hundred eighty (180) days prior to the expiration of this agreement. This agreement will then be extended under the same terms unless the parties agree to renegotiated terms.

4. The City agrees to provide an average of 340,000 gallons of treated wastewater each day from the mechanical Wastewater Treatment Plant. The

quality of treated wastewater will be at least equal to the KDHE discharge requirements for the City. Any significant amount of treated wastewater provided in excess of 400,000 gallons per day will require renegotiation of the price for said wastewater.

5. ADM has constructed one (1) pump station located at the wastewater facility. ADM shall maintain the entire pipeline with additional pumping units as necessary. The City will not be responsible for the treated wastewater once it enters the pump station/pipeline constructed by ADM and ADM understands that it is solely responsible for the wastewater once it enters the transfer system.

6. It shall be the sole responsibility of ADM to obtain any permits or other permission required from any regulatory agency for operation of the pump station and pipeline and use of the wastewater. ADM will assume the responsibility for and hold the City harmless and indemnify the City for any damage arising from the operation of the pump station and pipeline or ADM's use of the wastewater unless such damage is the result of negligence on the part of the City or its employees.

7. Any subcontractor utilized by ADM for the operation or maintenance of the pump station or pipeline shall carry insurance and bonding and take responsibility for any damages caused by said subcontractor and shall provide proof of such insurance and bonding before performing any duty on City property. ADM will place in effect a liability insurance policy to cover its operations in an amount not less than \$1,000,000 and the City will be named as an additional insured. ADM also agrees to provide worker's compensation insurance on all ADM employees that are utilized at any City site. A copy of the insurance certificates will be placed on file with the City Clerk's office in a form satisfactory to the City prior to any ADM employee performing work on City property.

8. ADM reserves the right, and the parties agree, that, in the event the water becomes unusable at ADM's biodiesel plant, ADM shall be allowed to terminate this agreement by giving sixty (60) days written notice to the City.

IN WITNESS WHEREOF, the parties have hereunto set their hands the day and year first above written.

ARCHER-DANIELS-MIDLAND COMPANY

Attest:

Corporate Secretary

THE CITY OF FORT SCOTT

By

JoLynne Mitchell, Mayor

(SEAL) ATTEST:

**Diane K. Clay
City Clerk**

CITY OF FORT SCOTT, KANSAS 66701

ESTABLISHED IN 1842®

Design Review Board February 15, 2018 4:00 p.m.

The Design Review Board met Thursday, February 15th, 2018 at 4:00 p.m. at the City Commission Meeting Room at 123 S. Main Street, Fort Scott, Kansas.

Arnold Schofield, Chairman called the meeting to order with roll call. Other board members present were: Darren Crays, and Shane Walker. Rick Zingre' and Peggy Cummings were absent. Rhonda Dunn, Community Development Director and Diane Clay, City Clerk represented the City Offices.

Others in attendance included: Jerry Witt and Jill Warford.

The first item on the agenda is consideration of the final approval of the Gordon Parks signage that will be placed on the side of the Iron Star Building.

Jill Warford shared a copy of the sign that was designed to be placed on the side of the Iron Star Building. This signage was approved earlier but she made some changes to the sign.

Darren Crays made a motion to approve the Gordon Parks sign. Shane Walker seconded. All voted aye.

APPROVED THE GORDON PARKS SIGN TO BE PLACED ON THE IRON STAR BUILDING.

The second item on the agenda was the installation of bicycle racks in the downtown area.

Shane Walker informed the Board that the bicycle racks that will be used are the racks that will hold two bicycles. The racks will be powder coated to match the street light colors in the downtown area. He said that this project is funded through the Pathways to a Healthy Bourbon County grant.

Rhonda Dunn asked that the Board not select any specific locations, but to leave that up to Chad Brown and Todd Farrell to determine the locations the bicycle racks are placed.

Darren Crays made a motion to approve the installation of the bicycle racks in the downtown area with the City determining where the racks will be placed. Shane Walker seconded. All voted aye.

APPROVED THE INSTALLATION OF THE BICYCLE RACKS IN THE DOWNTOWN AREA WITH THE CITY DETERMINING THE PLACEMENT OF THE BICYCLE RACKS.

Other Business:

Jerry Witt was present and visited with the Board about some changes to his building at 9 North Main Street. He will come back before them at a later date.

Rhonda Dunn updated the Board on the Union Block building. The City is waiting to hear if this building qualified for the grant from the State of Kansas.

Rhonda updated them on the Stout building and discussed renovation of the building versus demolition of the building. The Design Review Board members were in agreement that they would like to see the building saved and not demolished.

Rhonda also discussed the fencing issue in the downtown area. The Board determined they would like to wait to discuss this fencing issue when all the board members are present.

ADJOURNMENT:

Shane Walker moved to adjourn the meeting at 4:58 p.m. Darren Crays seconded. All voted aye.

Meeting adjourned at 4:58 p.m.

Respectfully submitted by:

Diane K. Clay, M.M.C.
City Clerk

CERTIFICATE OF APPROPRIATENESS
FORT SCOTT "H" HISTORIC DISTRICT
ADDITION/ ALTERATION TO EXISTING STRUCTURE

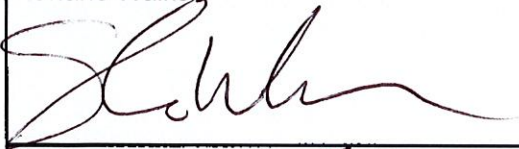
Name of Applicant: Shane Walker	Date: Phone #: 1/05/2017 224-6838
Name of Business: Healthy Bourbon County Trails and Connections	
Address of Proposed Changes: Downtown/Several Locations-See Attached Map	
Application Received By:	Date Received:
ADDITION/ ALTERATION TO EXISTING STRUCTURE	
<p>Photographs of Existing Building: Views taken close and at distance to help visualize the building, the proposed changes and the surrounding area.</p> <p>Elevations of Proposed Work: Scaled elevation drawings of all facades that will be viewed from any street within the District.</p> <p>Materials List: Full list of exterior materials and color samples. Material samples may be required (see staff).</p>	
Description of Proposed Changes:	
<p>On behalf of the Healthy Bourbon County Action group I am requesting to install bike racks in several locations downtown. Our hope is by doing this it will allow more people to ride their bikes to work and to do business downtown without fear of their bikes being damaged or stolen. The racks are designed to fit into to any urban enviroment and the ones I have singled out are made of and powder coated to match the downtown sign posts and lamps. There is one example of these already in use at the chamber office on the north side. This group has work very hard to make improvements in our area for activities to foster a healthier enviroment and offer healthy activities in our community.</p> <p>Thank You Shane Walker</p> 	
Design Review Board: <input checked="" type="checkbox"/> Recommend <input type="checkbox"/> Not Recommend	
Comments: <i>Recommended with tentative location as submitted final location by Director of Public Works</i>	
Chairman: <i>Culd W. Sheffield</i>	Date: <i>2/15/18</i>
Fort Scott City Commission: <input type="checkbox"/> Approved <input type="checkbox"/> Disapproved	
Comments:	
Mayor:	Date:

Quantity	Number of Loops	Location
3	1 Loop	Main Street: 1 middle of each block from Papa Dons area to 2 nd street
2	3 Loops	Health Dept and McDonalds
8	5 Loops	<p>Variety of Parking Lots:</p> <ol style="list-style-type: none"> 1. Scubitz Plaza parking; 2. parking across from pub/sharkys area; 3. Parking across from Old Spoiled Brat Building; 4. Parking Across from Winery, 5. Parking lot on 1st next to gazebo, 6. parking lot across from landmark and Witt's 7. Gunn Park 8. Riverfront Park



3 Loop across from beau arts
&
3 individual 1 loop on main

3 Loop parking lot

3 Loop parking lot

3 Loop at riverfront

3 Loop parking lot

3 Loop at Health Department

3 Loop parking lot

3 Loop cheney witt

3 Loop Gunn Park

3 Loop at Mcdonald's



Simple Security

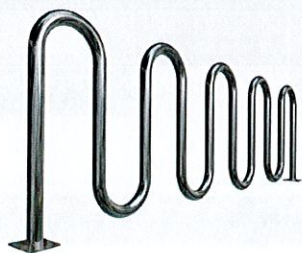

The graceful design and high security of the WAVE RACK has made this type of bike rack a standard for many schools and communities. The WAVE RACK can be used as a single-sided or double-sided parking bike rack. This rack uses thick pipe construction and allows for one of the wheels and frame to be secured using a u-style bike lock.



Simple Security

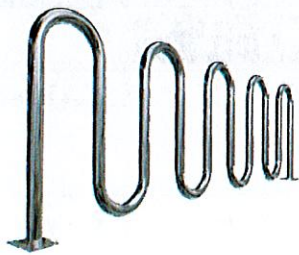

The graceful design and high security of the WAVE RACK has made this type of bike rack a standard for many schools and communities. The WAVE RACK can be used as a single-sided or double-sided parking bike rack. This rack uses thick pipe construction and allows for one of the wheels and frame to be secured using a u-style bike lock.

WAVE RACK

Submittal Sheet

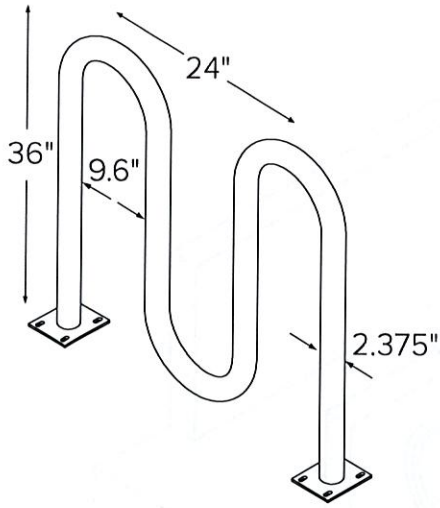

CAPACITY

509-2022: 5 Bikes
509-2023: 7 Bikes
509-2024: 9 Bikes
509-2025: 11 Bikes

MATERIALS

- Standard**
2.375" OD Schedule 40 Steel Pipe
- Lightweight**
2.375" OD Schedule 10 Steel Pipe

FINISHES

- Galvanized**
An after fabrication hot dipped galvanized finish is our standard option.
- Powder Coat**
Our powder coat finish assures a high level of adhesion and durability by following these steps:
1. Sandblast
2. Epoxy primer electrostatically applied
3. Final thick TGIC polyester powder coat
- Thermoplastic**
In addition to an increased thickness (8-10mils), the thermoplastic finish covers a galvanized layer and offers superior impact resistance over powder coating.
- Stainless**
Stainless Steel: 304 grade stainless steel material finished in either a high polished shine or a satin finish.

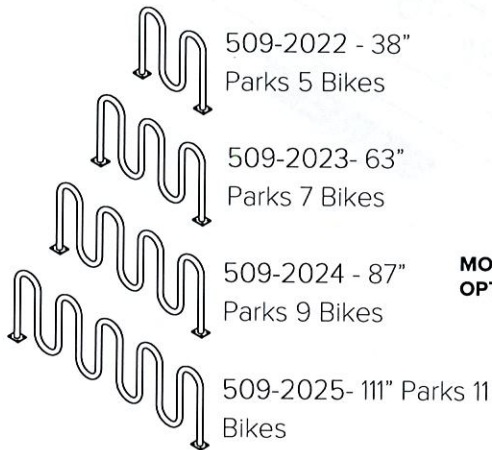

MOUNT OPTIONS

- In-ground**
In ground mount is embedded into concrete base. Specify in ground mount for this option.
- Surface**
Foot Mount has two 5"x6"x.25" feet with four anchors per foot. Specify foot mount for this option.

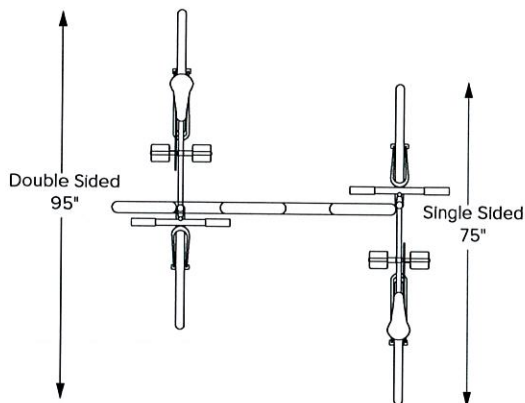

WAVE RACK

Submittal Sheet

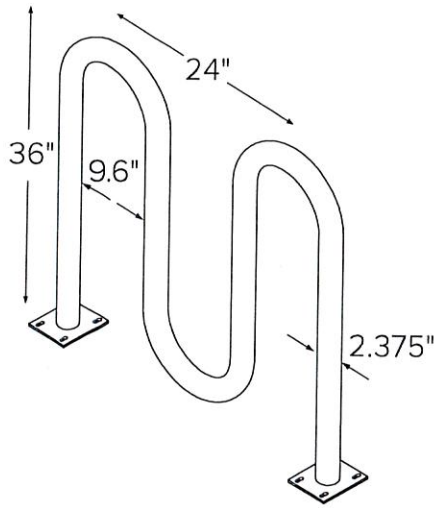

CAPACITY

509-2022: 5 Bikes
 509-2023: 7 Bikes
 509-2024: 9 Bikes
 509-2025: 11 Bikes

MATERIALS

- Standard**
2.375" OD Schedule 40 Steel Pipe
- Lightweight**
2.375" OD Schedule 10 Steel Pipe

FINISHES

- Galvanized**
An after fabrication hot dipped galvanized finish is our standard option.
- Powder Coat**
Our powder coat finish assures a high level of adhesion and durability by following these steps:
 1. Sandblast
 2. Epoxy primer electrostatically applied
 3. Final thick TGIC polyester powder coat

- Thermoplastic**
In addition to an increased thickness (8-10mils), the thermoplastic finish covers a galvanized layer and offers superior impact resistance over powder coating.
- Stainless**
Stainless Steel: 304 grade stainless steel material finished in either a high polished shine or a satin finish.

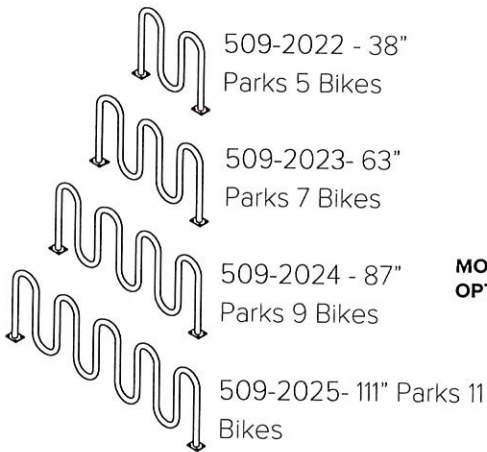

MOUNT OPTIONS

- In-ground**
In ground mount is embedded into concrete base. Specify in ground mount for this option.
- Surface**
Foot Mount has two 5"x6"x.25" feet with four anchors per foot. Specify foot mount for this option.

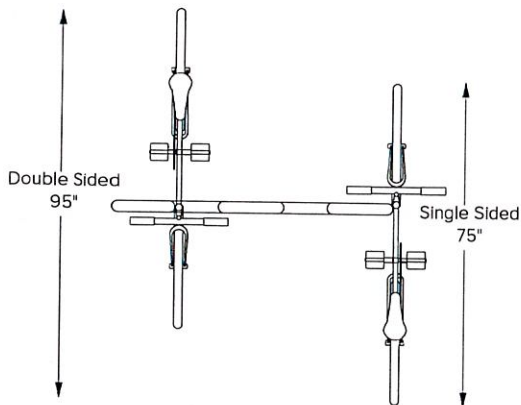

WAVE RACK

Installation Instructions – Surface Mount

TOOLS NEEDED

Tape Measure
Marker or Pencil
Masonry Drill Bit
Drill (Hammer drill recommended)
Hammer
Wrench or ratchet 9/16"
Level

RECOMMENDED BASE MATERIAL

Solid concrete is the best base material for installation. To ensure the proper anchors are shipped with your rack, ask your Park and Facilities representative which anchor is appropriate for your application. Be sure nothing is underneath the base material that could be damaged by drilling.

1

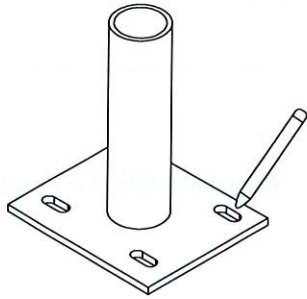

Place the rack in the desired location. Use a marker or pencil to outline the holes of the flange onto the base material.

2

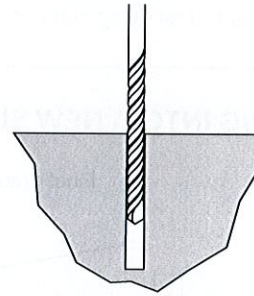

Drill 3/8" diameter holes 3" deep into surface. Make sure the holes are at least 3" away from any cracks in the base material.

3

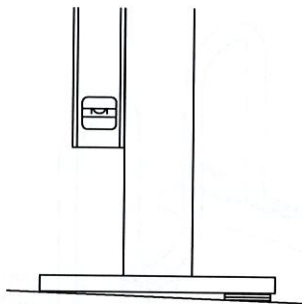

Place rack (and washers to level rack if necessary) over holes.

4

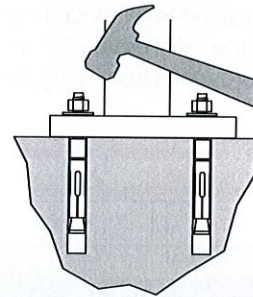

Thread nuts onto anchors, leaving approximately 1/4" of the anchor protruding, and tap into surface. Tighten nuts down to secure rack.

WAVE RACK

Installation Instructions – Surface Mount

TOOLS NEEDED

Tape Measure
Marker or Pencil
Masonry Drill Bit
Drill (Hammer drill recommended)
Hammer
Wrench or ratchet 9/16"
Level

RECOMMENDED BASE MATERIAL

Solid concrete is the best base material for installation. To ensure the proper anchors are shipped with your rack, ask your Park and Facilities representative which anchor is appropriate for your application. Be sure nothing is underneath the base material that could be damaged by drilling.

1

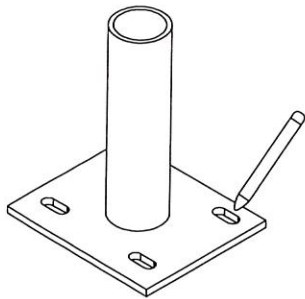

Place the rack in the desired location. Use a marker or pencil to outline the holes of the flange onto the base material.

2

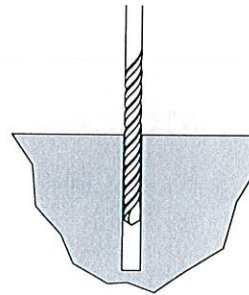

Drill 3/8" diameter holes 3" deep into surface. Make sure the holes are at least 3" away from any cracks in the base material.

3

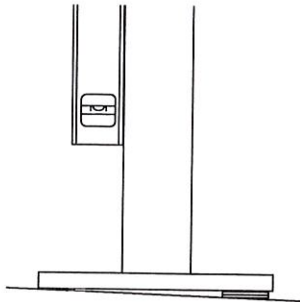

Place rack (and washers to level rack if necessary) over holes.

4

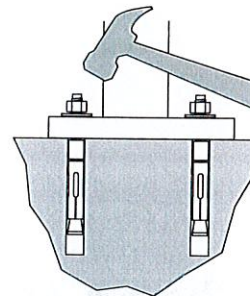

Thread nuts onto anchors, leaving approximately 1/4" of the anchor protruding, and tap into surface. Tighten nuts down to secure rack.

Welcome to
FORT SCOTT
Kansas

EST 1842



Boyhood Home of **GORDON PARKS**

Visit

 The Gordon Parks Museum
at Fort Scott Community College

 The Gordon Parks Photo Exhibit
at Mercy Hospital Fort Scott

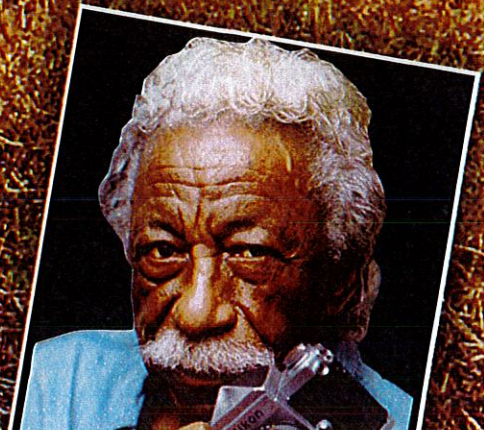

CITY OF FORT SCOTT, KANSAS 66701

ESTABLISHED IN 1842®

Fort Scott Planning Commission February 1st, 2018 4:00 p.m.

The Fort Scott Planning Commission met on Thursday, February 1st, 2018 at 4:00 p.m. in the City Commission meeting room. Board members present were: Pam Hightower, Carol MacArthur, Mitch Quick, Jared Leek, Mark McCoy, Darcy Smith, and Diana Endicott. Geoffrey Clark and Mark Lewis were absent.

Audience in attendance: Shirlee Mayfield, Patrick Wood, Jake Gross, Bob Eckles, Michael Newberry, Crystal Mason, Deborah Crawford, and Mike Tinsley. Rhonda Dunn, Community Development Director, Rachel Pruitt, Economic Development Director, and Diane Clay, City Clerk represented the City Offices.

Diana Endicott, Chairperson called the meeting to order. She said the first item on the agenda is to consider a zoning change on two tracts of property. A change of zoning from R-2 (Medium Density Residential District) to MU (Mixed Use District) – For Tract #1 at 1907 S. Horton and A change of zoning from R-2 (Medium Density Residential District) to R-3 (High Density Residential District) for Tract #2 at 1920 S. Huntington.

Rhonda Dunn shared a map with the Board of the proposed property. This property was purchased by Two Dogs Barking, LLC which is Patrick Wood and Jake Gross. There is approximately 5.83 acres total which they plan to develop. She thanked them for the cleanup of the property at this location.

Patrick Wood informed the Board that they plan to put retail businesses into the property along Horton Street. They are planning to look into a TIF grant to assist with the property and sales tax. They would put a 4,000' strip mall along Horton Street. They would look at possible housing on the Huntington Street location. They are undecided on the type of housing they would put there. It could be higher end apartments and not just college apartments. They may put duplexes there also similar to the units on Osburn and Burke Streets.

Several neighbors in the audience including Shirlee Mayfield, Bob Eckles, and Mike Tinsley asked questions regarding the type of housing that would be built there, fencing, if any, would be installed, and if sidewalks would be installed.

Patrick Wood and Jake Gross answered the questions they had. They said that the retail would be constructed first before any sidewalks. They relayed to the audience that whatever housing is put there will look very nice and it will be landscaped and maintained.

Mitch Quick made a motion to recommend the zoning change from R-2 (Medium Density Residential District) to MU (Mixed Use District) – For Tract #1 at 1907 S. Horton. Pam Hightower seconded. Jared Leek and Carol MacArthur abstained from voting. All other members voted aye. Motion carried 5-2.

APPROVED TO RECOMMEND THE ZONING CHANGE FROM R-2 (MEDIUM DENSITY RESIDENTIAL DISTRICT) TO MU (MIXED USE DISTRICT) – FOR TRACT #1 AT 1907 S. HORTON.

Mark McCoy made a motion to recommend the zoning change from R-2 (Medium Density Residential District) to R-3 (High Density Residential District) for Tract #2 at 1920 S. Huntington. Darcy Smith seconded. Jared Leek abstained. All voting members voted aye. Motion carried 6-1.

APPROVED TO RECOMMEND THE ZONING CHANGE FROM R-2 (MEDIUM DENSITY RESIDENTIAL DISTRICT) TO R-3 (HIGH DENSITY RESIDENTIAL DISTRICT) FOR TRACT #2 AT 1920 S. HUNTINGTON.

Diana Endicott informed the property owners as well as the audience that this will be heard at the February 20th, 2018 City Commission meeting for their approval.

The Board then went over Chapter 9. There will be another meeting of the Planning Commission held on February 26th, 2018 at 4:00 p.m. to review the complete proposed Comprehensive Plan. This plan will be presented to the City Commission at their March 6th, 2018 meeting to review and approve.

Mark McCoy moved to adjourn the meeting at 4:57 p.m. Darcy Smith seconded. All voted aye.

Meeting adjourned at 4:57 p.m.

Respectfully submitted,

Diane K. Clay, MMC, City Clerk



CITY OF FORT SCOTT, KANSAS 66701

ESTABLISHED IN 1842 ®

NOTICE OF PUBLIC HEARING FOR AMENDMENT TO ZONING ORDINANCE

OFFICIAL NOTICE

TO WHOM IT MAY CONCERN AND TO ALL PERSONS INTERESTED:

NOTICE IS HEREBY GIVEN that on **February 1st, 2018**, the Fort Scott Planning Commission, will meet at the City Commission Meeting Room, 123 S. Main, Fort Scott, Kansas, at **4:00 P.M.**, to consider the following application:

A change of zoning from R-2 (Medium Density Residential District) to MU (Mixed Use District) – For Tract #1

and

A change of zoning from R-2 (Medium Density Residential District) to R-3 (High Density Residential District) for Tract #2

CASE NO. 1080

Tract #1 – Lots 1, 2, 7, 9, 11, 13, 15 and the West 37.5 feet of Lot 3, all in Block 8, in South Side Park Addition to the City of Fort Scott, Bourbon County, Kansas.

Tract #2 - The East 12.5 feet of Lot 3, all of Lots 4, 5, 6, 8, 10, 12 and 14, in Block 8, and Lots 1, 2, 3, 7, 9, 11, 13, and 15, in Block 9, and the South ½ of Vacated Huntington Blvd., lying North of the east 12.5 feet of Lot 3, and North of Lots 4 and 5, Block 8, and Lots 1, 2, and 3, Block 9, and the vacated portion of Huntington Blvd. adjoining the east side of Lots 5, 6, 8, 10, 12 and 14, Block 8, and the west side of Lots 1, 7, 9, 11, 13, and 15, Block 9, all located in the South Side Park Addition to the City of Fort Scott, Bourbon County, Kansas.

More commonly known as: 1907 S. Horton and 1920 S. Huntington, Fort Scott, Kansas 66701.

As provided in the Zoning Ordinance of Fort Scott, Kansas, the above application will be discussed and considered by the Planning Commission, and recommendations will be made to the Governing Body. All persons interested in said matter will be heard at this concerning their views and wishes; and any protest against any of the provisions of the proposed changes to the Zoning Ordinance will be considered by the Board.

Rhonda Dunn
Community Development Director



TWO DOGS
— BARKING, LLC —

Application for Change of Zoning

Application For Change of Zoning Fort Scott, Kansas

1. **Applicant:** Two Dogs Barking, LLC **Phone:** 620-224-7163
2522 Richards Rd. **Email:** patrickw@2dogsrei.com
Fort Scott, KS 66701
2. **Agent:** Patrick Wood **Phone:** 620-224-7163
3. **Applicant's interest in the property that is the subject of this application:**
Owner/Developer
4. **Applicant hereby requests a change of zoning from:**
Tract #1 R-2 to Mixed Use
Tract #2 R-2 to R-3

The property for which this change is requested is legally described as:

Tract 1:

Lots 1, 2, 7, 9, 11, 13, 15 and the West 37.5 feet of Lot 3, all in Block 8, In South Side Park Addition to the City of Fort Scott, Bourbon County, Kansas

Tract 2:

The East 12.5 feet of Lot 3 all of Lots 4, 5, 6, 8, 10, 12 and 14, in Block 8 and Lots 1, 2, 3, 7, 9, 11, 13, and 15, in Block 9, the South Half of vacated Huntington Blvd. North of the East 12.5 feet of Lot 3, and North of Lots 4 and 5, Block 8, and Lots 1, 2 and 3, Block 9 and the vacated portion of Huntington Blvd. adjoining the east side of Lots 5, 6, 8, 10, 12 and 14 Block 8 and the west side of Lots 1, 7, 9, 11, 13 and 15, Block 9, all located in the South Side Park Addition to the City of Fort Scott, Bourbon County, Kansas.

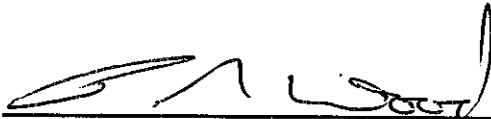

Patrick Wood, Member
Two Dogs Barking, LLC

Tract 1

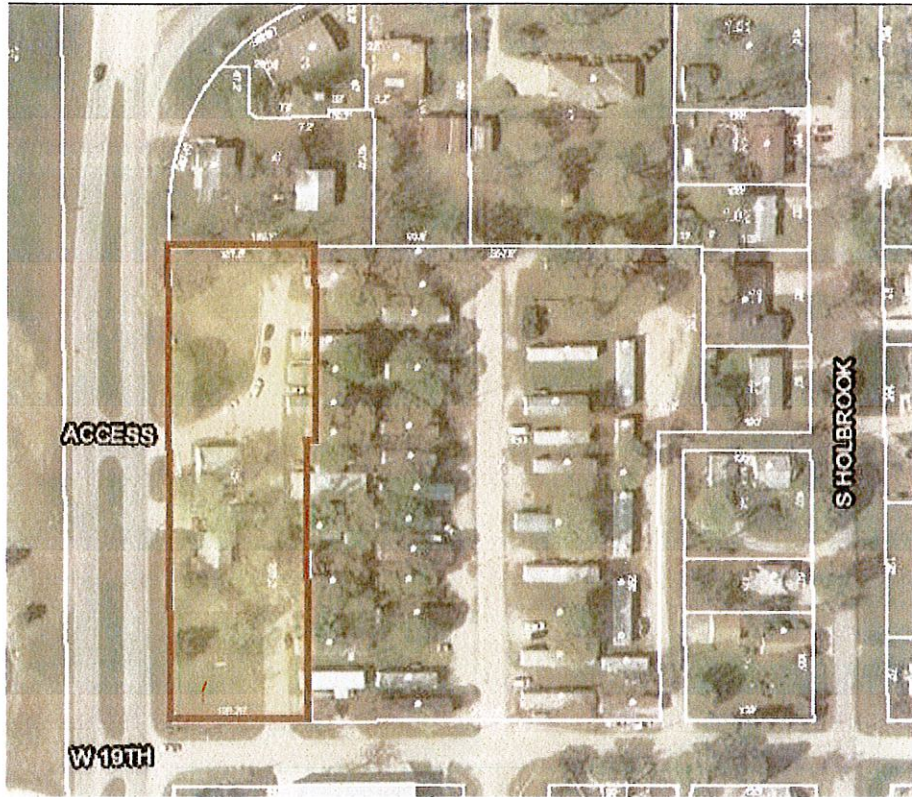

Tract 2

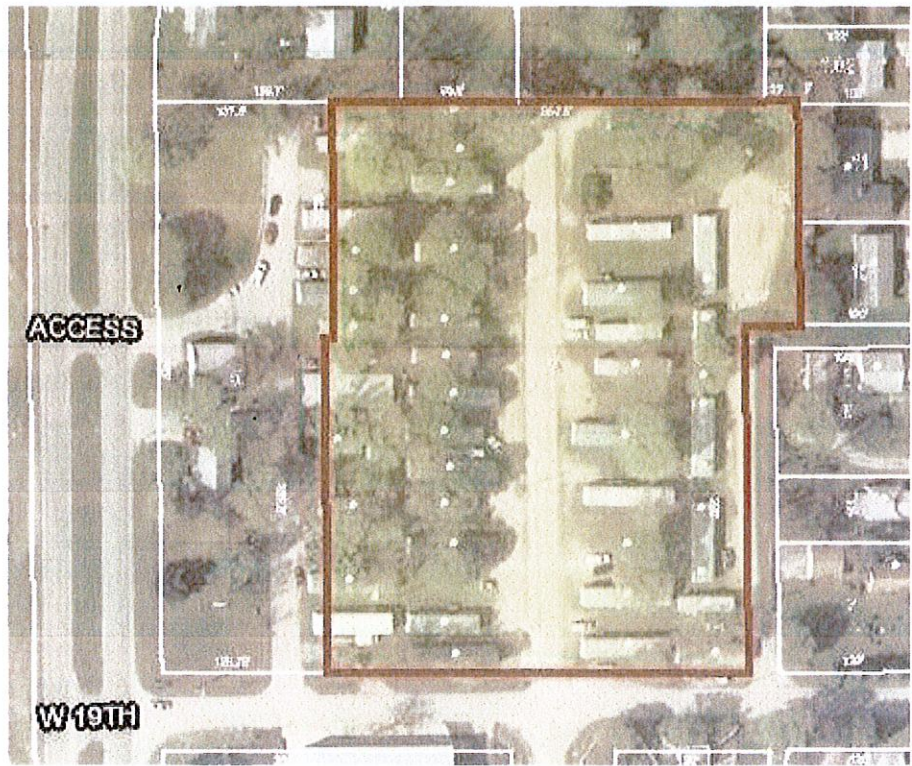

Executive Summary

Development Site

The development area is commonly known as the "Fairmont Mobile Home Park". Located at 1907 S. Horton and 1920 Huntington Blvd.

Site Characteristics

- Currently this property is broken up into different parcels.
 1. 1907 S. Horton, Fort Scott, KS. This property is the furthest west parcel. It currently consists of a 2 bedroom home with a single car detached garage and a shop building.
 2. 1920 Huntington, Fort Scott, KS. This property consists of approximately 30 mobile home sites. The mobile homes have been removed and only the pad sites remain.

Site Strengths

The close proximity to the Fort Scott Community College makes this site applicable for multi-family housing. The traffic on Horton is appealing as a means of advertising.

Market Conditions

In 2015, the City of Fort Scott did a feasibility analysis of student apartments. The study found that there was a 4% vacancy rate in Fort Scott apartments, while the national average is around 8%. 4% vacancy is very low average for a city the size of Fort Scott, nonetheless the majority of that 4% came from one apartment building while many of the others had close to 0% vacancy. This study also stated that there is adequate demand for an additional 64 unit apartment complex at market rate.

Proposal

Two Dogs Barking, LLC is proposing to build multifamily and retail on Tract #1. The plan allows for up to 24 multifamily units and/or up to 8000 square feet of retail space. Tract #2 is still in the planning and negotiating stage. It will be some form of housing.

The vision promotes a successful, healthy lifestyle within a vibrant, active community. Fort Scott residents and apartment tenants will find balance between business, life, and education. Apartments are the remedy for a property that has severely deteriorated and a college that needs student housing.

Contacts

Developer

Two Dogs Barking, LLC
C/O Patrick Wood & Jake Gross
2522 Richards Rd
Fort Scott, KS 66701

Patrick Wood

Cell: 620-224-7163

Email: patrickw@2dogsrei.com

Jake Gross

Cell: 620-224-0388

Email: jakeg@2dogsrei.com

APPLICATION FOR
CHANGE OF ZONING
FORT SCOTT, KANSAS

1. APPLICANT Two Dogs Baking PHONE (620) 224-7163
- ADDRESS 2522 Rockwell Rd FAX ()
Fort Scott, KS E-mail patrickw@2dogsbak.com
66701
- NAME OF AGENT (if any) Patrick Wood PHONE (620) 224-7163
- ADDRESS Same FAX ()
E-mail Same

2. APPLICANT'S INTEREST IN THE PROPERTY THAT IS THE SUBJECT OF THIS APPLICATION: Owner / Developer

3. APPLICANT HEREBY REQUESTS A CHANGE OF ZONING FROM Parcel #1 R-2 to Mixed use ZONING DISTRICT TO Parcel #2 R-2 to R-3 ZONING DISTRICT.

THE PROPERTY FOR WHICH THIS CHANGE IS REQUESTED IS LEGALLY DESCRIBED AS:

(use either metes and bounds or subdivision/block/lot description)

Tract 1: Lots 1, 2, 7, 9, 11, 13, 15 and west 37.5 feet of lot 3, all in block 8, in South Side Park addition to the city of Fort Scott, KS

Tract 2: The east 12.5 feet of lot 3 all of lots 4, 5, 6, 8, 10, 12 and 15 in block 9, south half of vacated Huntington Blvd. north of the east 12.5 feet of lot 3 and north of lots 4 and 5, Block 8, and lots 1, 2, 3 of block 9, and vacated portion of Huntington Blvd. adjoining the east side of lots 5, 6, 8, 10, 12 and 14 Block 8 and west side of lots 1, 7, 9, 11, 13 and 15, Block 9 all located in South Side Park Addition City of Fort Scott, KS

FOR OFFICIAL USE ONLY

FILE NO.:	
DATE FILED:	
FEE PAID:	
RECEIVED BY:	
DATE ADVERTISED	
DATE NOTICES SENT	
PUBLIC HEARING DATE:	

PLANNING COMMISSION RECOMMENDATION _____

REASON FOR RECOMMENDATION _____

VALID PROTEST PETITION FILED? _____

GOVERNING BODY ACTION _____

DATE: _____ VOTE: _____

IF APPROVED, ORDINANCE NO.: _____

EFFECTIVE DATE OF ORDINANCE: _____

(Published in the Fort Scott, Kansas, Daily Tribune-Monitor on _____, 20__).

ORDINANCE NO. 3530

AN ORDINANCE CHANGING THE ZONING CLASSIFICATIONS OR DISTRICTS OF CERTAIN LANDS LOCATED IN THE CITY OF FORT SCOTT, KANSAS, UNDER THE AUTHORITY GRANTED BY K.S.A. 1973 SUPP. 12-708.

SECTION 1. That having received a recommendation from the Planning Commission, and proper notice having been given and hearing held as provided by law and under authority and subject to the provisions of K.S.A. 1973 SUPP. 12-708, the zoning classification or districts of the property described hereby are changed as follows:

A change of zoning from R-2 (Medium Density Residential District) to MU (Mixed Use District) – For Tract #1

Property described as: Tract #1 – Lots 1, 2, 7, 9, 11, 13, 15 and the West 37.5 feet of Lot 3, all in Block 8, in South Side Park Addition to the City of Fort Scott, Bourbon County, Kansas

More commonly known as: 1907 S. Horton Street, Fort Scott, Kansas.

SECTION 2. That upon the taking effect of this ordinance, the above zoning changes shall be entered and shown on the “Official Zoning Map” previously adopted by reference, in Ordinance No. 2992 and said Official Zoning Map is hereby reincorporated as a part of the Zoning Ordinance as amended.

SECTION 3. That this ordinance shall take effect and be in force from and after its adoption and publication in the official City paper.

ADOPTED AT FORT SCOTT, KANSAS THIS 20th DAY OF February, 2018.

(SEAL)

ATTEST:

Diane K. Clay, City Clerk

JoLynne Mitchell, Mayor

(Published in the Fort Scott, Kansas, Daily Tribune-Monitor on _____, 20__).

ORDINANCE NO. 3531

AN ORDINANCE CHANGING THE ZONING CLASSIFICATIONS OR DISTRICTS OF CERTAIN LANDS LOCATED IN THE CITY OF FORT SCOTT, KANSAS, UNDER THE AUTHORITY GRANTED BY K.S.A. 1973 SUPP. 12-708.

SECTION 1. That having received a recommendation from the Planning Commission, and proper notice having been given and hearing held as provided by law and under authority and subject to the provisions of K.S.A. 1973 SUPP. 12-708, the zoning classification or districts of the property described hereby are changed as follows:

A change of zoning from R-2 (Medium Density Residential District) to R-3 (High Density Residential District) for Tract #2

Tract #2 - The East 12.5 feet of Lot 3, all of Lots 4, 5, 6, 8, 10, 12 and 14, in Block 8, and Lots 1, 2, 3, 7, 9, 11, 13, and 15, in Block 9, and the South ½ of Vacated Huntington Blvd., lying North of the east 12.5 feet of Lot 3, and North of Lots 4 and 5, Block 8, and Lots 1, 2, and 3, Block 9, and the vacated portion of Huntington Blvd. adjoining the east side of Lots 5, 6, 8, 10, 12 and 14, Block 8, and the west side of Lots 1, 7, 9, 11, 13, and 15, Block 9, all located in the South Side Park Addition to the City of Fort Scott, Bourbon County, Kansas.

More commonly known as: 1920 S. Huntington Street, Fort Scott, Kansas.

SECTION 2. That upon the taking effect of this ordinance, the above zoning changes shall be entered and shown on the "Official Zoning Map" previously adopted by reference, in Ordinance No. 2992 and said Official Zoning Map is hereby reincorporated as a part of the Zoning Ordinance as amended.

SECTION 3. That this ordinance shall take effect and be in force from and after its adoption and publication in the official City paper.

ADOPTED AT FORT SCOTT, KANSAS THIS 20th DAY OF February, 2018.

(SEAL)

ATTEST:

Diane K. Clay, City Clerk

JoLynne Mitchell, Mayor



Buck Run Community Center

February 15, 2018

To: Jon Garrison – Finance Director – City of Fort Scott
From: Tom Robertson – BRCC Manager
Subject: Equipment Bids for BRCC Fitness Club

Based on the bids we received on Wednesday, February 14, 2018, I would recommend accepting the bid received from Mid-States Fitness Equipment totaling \$9,300.00.

The bid amounts that were less than \$9,300.00, did not specifications that was required on the quote sheet sent out. Mid-States Fitness Equipment met all requirements concerning service and warranty as well.

Please let me know if you have any questions or concerns on this matter or if you need anything else on the purchase.

Thanks,

Tom Robertson

BID SHEET - CITY OF FORT SCOTT

Bid Date: February 14, 2018 - 10:00 a.m.

**CITY OF FORT SCOTT
Project: Fitness Equipment - Buck Run**

Item No. and Description	Bidder Name & Address		Bidder Name & Address		Bidder Name & Address	
	Unit Price	Item Total	Unit Price	Item Total	Unit Price	Item Total
	700 Series	\$ 8,132.00	\$ 8,449.82		\$ 9,300.00	
	625T	\$ 9,390.00				
Incline Trainer Treadmill	770T	\$ 9,990.00				
	Bidder Name & Address		Bidder Name & Address		Bidder Name & Address	
	2nd Wind 2703 E Broadway Columbia, MO 65201		Foremost Fitness 1122 Spring Lilly Court High Ridge, MO 63049		Home Fitness 2260 N Rock Road Wichita, KS 67226	
	Unit Price	Item Total	Unit Price	Item Total	Unit Price	Item Total
Incline Trainer Treadmill	(Matrix)	\$ 9,863.00	\$ 9,998.00		\$ 9,999.98	
	(Landice)	\$ 9,581.00				
	Bidder Name & Address		Bidder Name & Address		Bidder Name & Address	
	Ortho Tech 1211 Weaver Road Herrin, IL 62948		Your Total Fitness Shop 4608 W Walnut-Ste C Rogers, Arkansas 72756		ProMaxima 5310 Ashbrook Houston, TX 77081	
	Unit Price	Item Total	Unit Price	Item Total	Unit Price	Item Total
Incline Trainer Treadmill		\$ 10,590.00	\$ 11,998.00		\$ 20,465.33	
TOTAL						

TOTAL THIS PAGE _____
GRAND TOTAL _____



MID-STATES FITNESS EQUIPMENT

KANSAS LARGEST FITNESS EQUIPMENT STORE

235 S. Topeka St.
Wichita, KS 67202

PROPOSAL

DATE	BID NUMBER
1/22/2018	12949

PROPOSAL FOR
Buck Run Community Center 735 Scott Ft. Scott, KS 66701

TERMS	Salesman	Shipping/Delivery Info.	Proposal Site
Net 30	CB		

QTY	DESCRIPTION	Best Price	Total Amount
2	BH Fitness LK 700Ti Treadmill Freight - Special Order Delivery & Installation Factory Warranty is: Frame - Lifetime / Motor - 5 years / Parts - 5 years / Labor - 2 years Mid-States will give a third year of labor warranty to meet specification of 3 years labor Parts warranty exceeds specification Unit has 500 lb weight capacity which meets specification. Government - Non-Taxable	4,325.00 150.00 500.00 0.00%	8,650.00T 150.00T 500.00T 0.00

Phone # 316-681-3611
Fax # 316-681-0769

TOTAL \$9,300.00



over 100 years of innovation

UPC 835126202669



Optional Extended Medical Rails Available on LK700Ti



LK700Ti treadmill

- HST Phenolic Resin comes standard and is unique to the market. It provides a maintenance free system, eliminating the need of lubrication for up to 2 years.
- Whisper quiet 5.0 HP AC drive motor provides unparalleled durability and reliability
- Extra large 22" x 63" running surface enables a safe and comfortable workout
- 17 Built-In Programs including Gerkin Protocol Fitness Test and Body Fat Calculator
- Refreshing 2 speed personal cooling fan motivates you to go the extra mile
- MP3 player compatible through a line-in connection. Audio is available through built-in speaker or headphone jack
- Orthopedic running belt provides a more comfortable, lower-impact workout experience
- Convenient crossbar controls enable speed and incline adjustments on the fly without losing focus on your workout
- Pre-drilled for Medical Rails (medical rails sold separately)

Download the free Pafers Apps for your compatible Apple® or Android® device



Use your tablet or smartphone to seamlessly interface with the equipment via Bluetooth®



Enjoy all of your favorite apps while exercising



SPECIFICATIONS

- Blue Backlit LCD Display
- Bluetooth Enabled iConcept Technology
- Polar® Heart Rate Strap Compatible
- Contact Heart Rate Grips
- HST Phenolic Resin
- Cooling Fan
- MP3 Player Connectivity
- Speakers
- 17 Built-in Programs
- 22" x 63" Running Surface
- 0.5-12.5 MPH & 0-15% Incline
- 5.0 HP AC Motor
- 3" Rollers
- Ortho Cushion Belt
- Active-Flex Suspension
- Fixed Safety Key
- Accessory Tray
- Removable Water Bottle Holders
- Pre-drilled for Medical Rails (medical rails sold separately)
- Broadcast Vision® Television Mounts Compatible

Club Commercial Warranty

Frame: Lifetime | Motor: 3 years | Parts: 3 years | Labor: 2 years
Club Commercial Disclaimer: For all dues paying facilities, regardless of usage.

Commercial Warranty

Frame: Lifetime | **Motor: 5 years | Parts: 5 years | Labor: 2 years**
Commercial Disclaimer: For non-dues paying facilities, with less than 8 hours of use per day.

Cosmetics Warranty Information:

For all products and all level of warranty, Cosmetic parts shall be warranted for 1 year from date of purchase against manufactures defect. "Cosmetics" includes: External plastics, overlays/decals and covers.

Measurements

	Max User	500 lbs.
Weight		447 lbs.
Step Up Height		8.5 in.

Assembled Dimensions

Length	89 in.
Width	34.5 in.
Height	58 in.

Box Dimensions

Length	90 in.
Width	38 in.
Height	17 in.

Note: All pricing and specifications are subject to change without notice



v2016

BH Fitness | 20155 Ellipse, Foothill Ranch, CA 92610
Toll Free: 866.325.2339 | Fax: 949.206.0350 | www.BHFitnessUSA.com



**Buck Run Community Center
Fitness Equipment Bid**

The City of Fort Scott is requesting bids for fitness equipment to be delivered/shipped to Buck Run Community Center. All items must include photos/web-site options to verify specifications. Fitness items needed are as follows:

- Incline Trainer Treadmill – Commercial (Quantity 2)
 - a. Maximum User Weight – 500 lbs.
 - b. Warranty – Frame Lifetime/ Motor 5 years/ Parts 3 years/Labor 3 years

All bids will be referred to City staff for final recommendation. Please address all bids to the attention of the City Clerk and the envelope should be marked "BRCC Fitness Equipment". **All bids should be received in the City Clerk's office by 11:00 a.m. Wednesday, February 14th, 2018.** The City of Fort Scott reserves the right to reject any and or all bids and the right to waive any irregularity in any bid.

Further information regarding this item may be obtained by contacting Tom Robertson, Director, Buck Run Community Center at 620-223-0386.

Fitness Showcase
7517 W. 119th Street
Overland Park, KS 66213-1107

Central States Fitness Systems
Attn: Darin Dew
12718 Sagamore Road
Leawood, Kansas 66209

Your Total Fitness Shop
Attn: Josh Feagans
4608 W. Walnut, Suite C
Rogers, Arkansas 72756

PR Fitness Equipment
Attn: Rob Goff
13716 N. Lincoln, Suite A
Edmond, Oklahoma 73013

Advanced Exercise Equipment
Attn: Jeff and Jodi Paxton
861 Southpark Dr., Suite 100
Littleton, Colorado 80120-5684

Fitness Gallery
10363 Metcalf Ave.
Overland Park, Kansas 66212

Mid-States Fitness Equipment
Attn: Craig Bally
235 S. Topeka
Wichita, Kansas 67202

Barrett Smith
3420 N.E. Akin Blvd #212
Lees Summit, Missouri 64064

Nautilus, Inc.
Attn: Wes Galloway
7412 E. Knoxville Street
Broken Arrow, OK 74014

Ortho Tec
1211 Weaver Road
P. O. Box 430
Herrin, IL 62948

Foremost Fitness Group, LLC
Attn: Cody Jackson
704 Heatherstone Drive
High Ridge, MO 63049

True Fitness Technology, Inc.
P. O. Box 790051
865 Hoff Road
St. Louis, MO 63366

*Mailed
1-17-18
de*

MEMORANDUM

TO: Dave Martin, City Manager

FROM: Jon Garrison, Director of Finance

DATE: February 15, 2018

SUBJECT: Natural gas supplier at Memorial Hall and Street Barn

Several weeks ago I was approached by Constellation New Energy – Gas Division, LLC about switching our natural gas supplier from Kansas Gas Service (KGS) to Constellation at Memorial Hall and the Public Works Building at 2101 Sidney. According to their analysis, we can annually save approximately \$1,194 at Public Works and \$1,459 at Memorial Hall.

If approved, please authorize the Mayor to sign the attached documents.

Thank you.

cc: Diane Clay, City Clerk

2101 Sidney
 2101 Sidney St
 Fort Scott, KS

KGS Acct # 510129508-1186260
 Meter # 0316B02549

	<u>2015</u>	<u>2016</u>	<u>2017</u>	<u>2018</u>	<u>Avg</u>	<u>Minimum</u>	<u>Load Factor</u>
Jan	354	305	328		329	305	93%
Feb	266	251	209		242	209	86%
Mar	238	114	130		161	114	71%
Apr	52	100	56		69	52	75%
May	17	13	51		27	13	46%
Jun	6	6	5		6	5	91%
Jul	5	4	5		5	4	74%
Aug	5	3	4		4	3	76%
Sep	5	3	5		4	3	79%
Oct	5	5	12		7	5	68%
Nov	96	12	13		40	12	30%
Dec	<u>184</u>	<u>196</u>	<u>120</u>		<u>167</u>	120	72%
Totals	1,231	1,012	939		1,061		

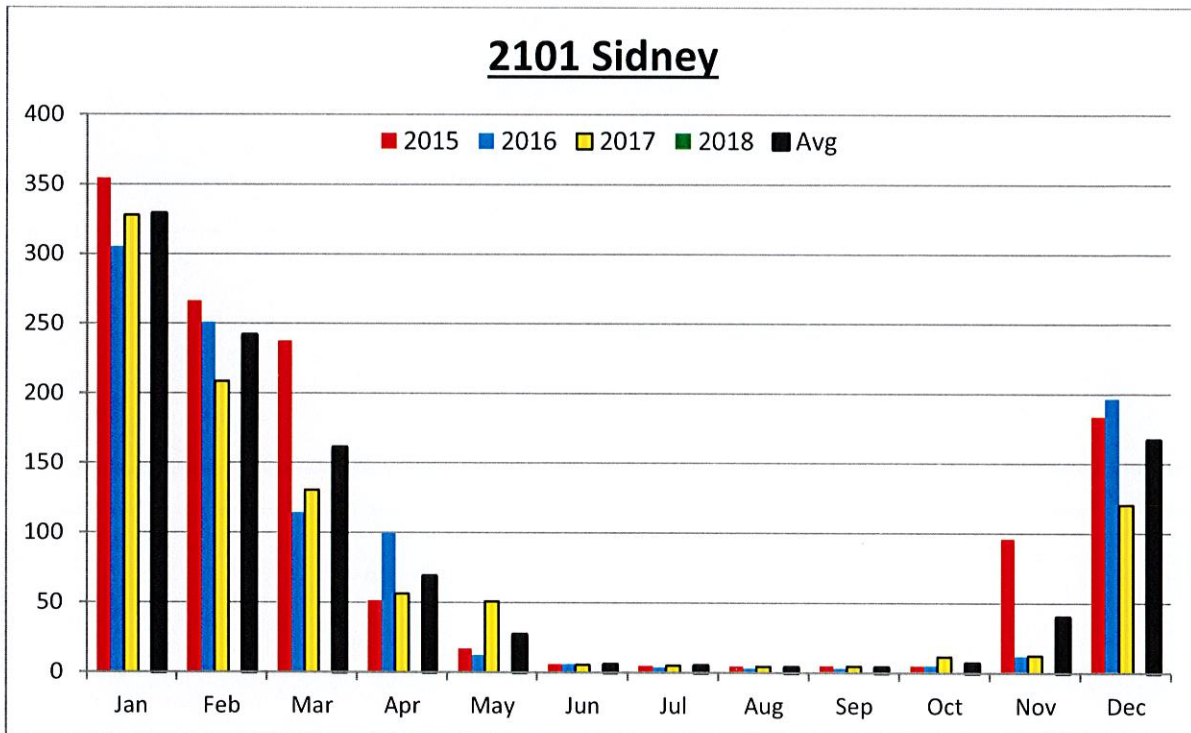

2101 Sidney

Transportation Program Performance

Year	Total		Program Savings	Avg \$	
	Total Sales Service	Transport Service		Savings per mcf	% Savings
2015	\$9,900	\$8,116	\$1,783	\$1.45	18%
2016	\$7,150	\$6,273	\$877	\$0.87	12%
2017	<u>\$7,058</u>	<u>\$6,135</u>	<u>\$923</u>	<u>\$0.98</u>	<u>13%</u>
total	\$24,108	\$20,524	\$3,583	\$1.13	15%

Average Annual Savings: \$1,194

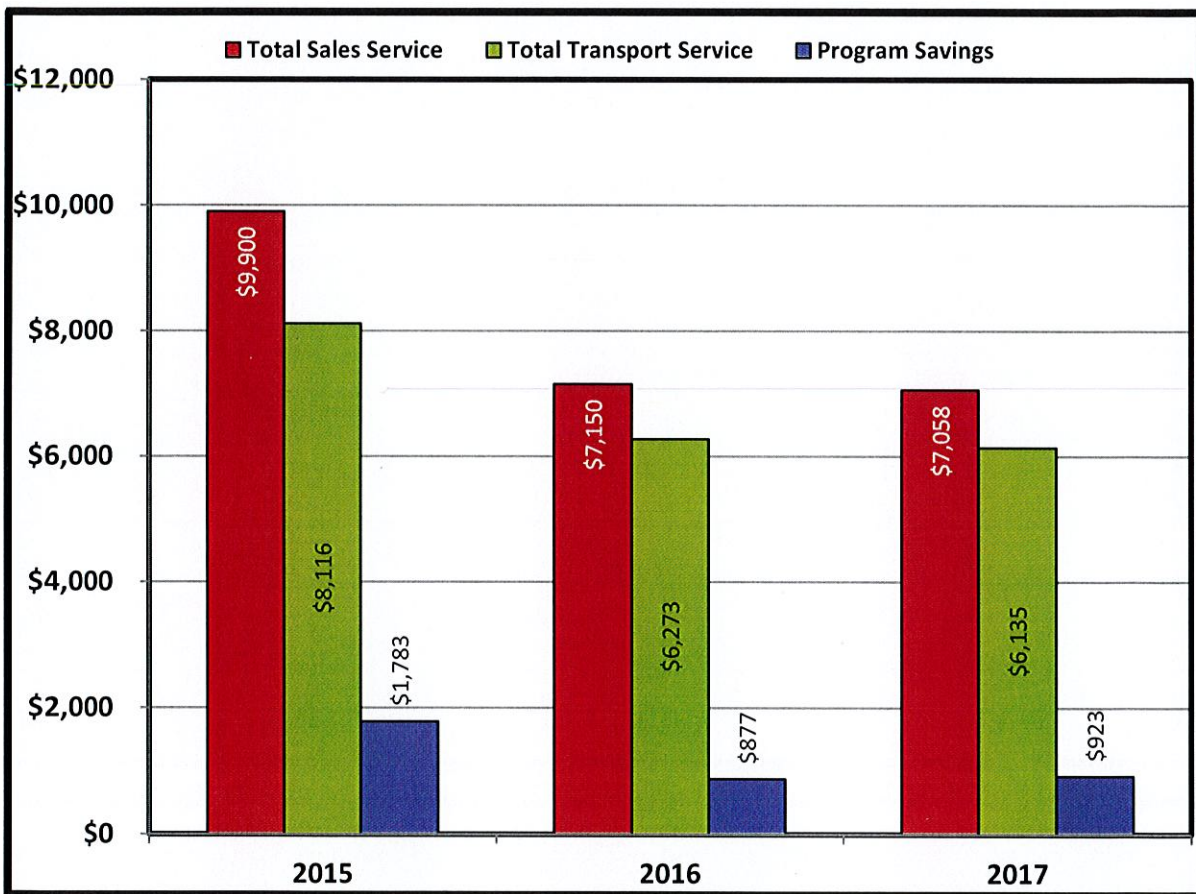

Memorial Hall
 1 E 3rd St
 Fort Scott, KS

KGS Acct # 510717550-1185317
 Meter # 302600242

	<u>2015</u>	<u>2016</u>	<u>2017</u>	<u>2018</u>	<u>Avg</u>	<u>Minimum</u>	<u>Load Factor</u>
Jan	478	376	370		408	370	91%
Feb	375	335	214		308	214	70%
Mar	157	149	157		154	149	97%
Apr	27	140	94		87	27	31%
May	2	27	69		33	2	5%
Jun	1	26	0		9	0	4%
Jul	0	0	0		0	0	#DIV/0!
Aug	0	0	0		0	0	#DIV/0!
Sep	0	0	0		0	0	#DIV/0!
Oct	0	0	0		0	0	#DIV/0!
Nov	15	0	99		38	0	0%
Dec	159	265	153		192	153	80%
Totals	1,215	1,318	1,156		1,229		

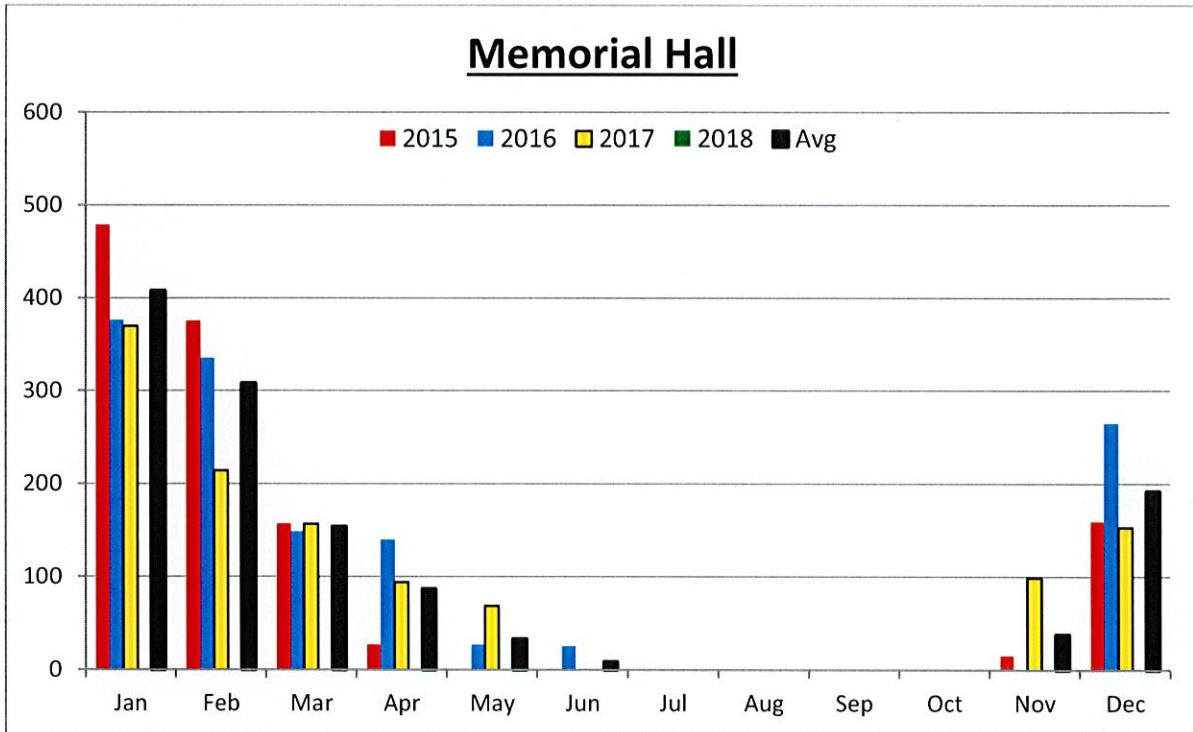

Memorial Hall

Transportation Program Performance

Year	Total		Program Savings	Avg \$	
	Total Sales Service	Transport Service		per mcf	% Savings
2015	\$10,074	\$8,184	\$1,890	\$1.55	19%
2016	\$9,143	\$7,906	\$1,237	\$0.94	14%
2017	<u>\$8,564</u>	<u>\$7,315</u>	<u>\$1,249</u>	<u>\$1.08</u>	<u>15%</u>
total	\$27,780	\$23,405	\$4,376	\$1.19	16%
Average Annual Savings:			\$1,459		

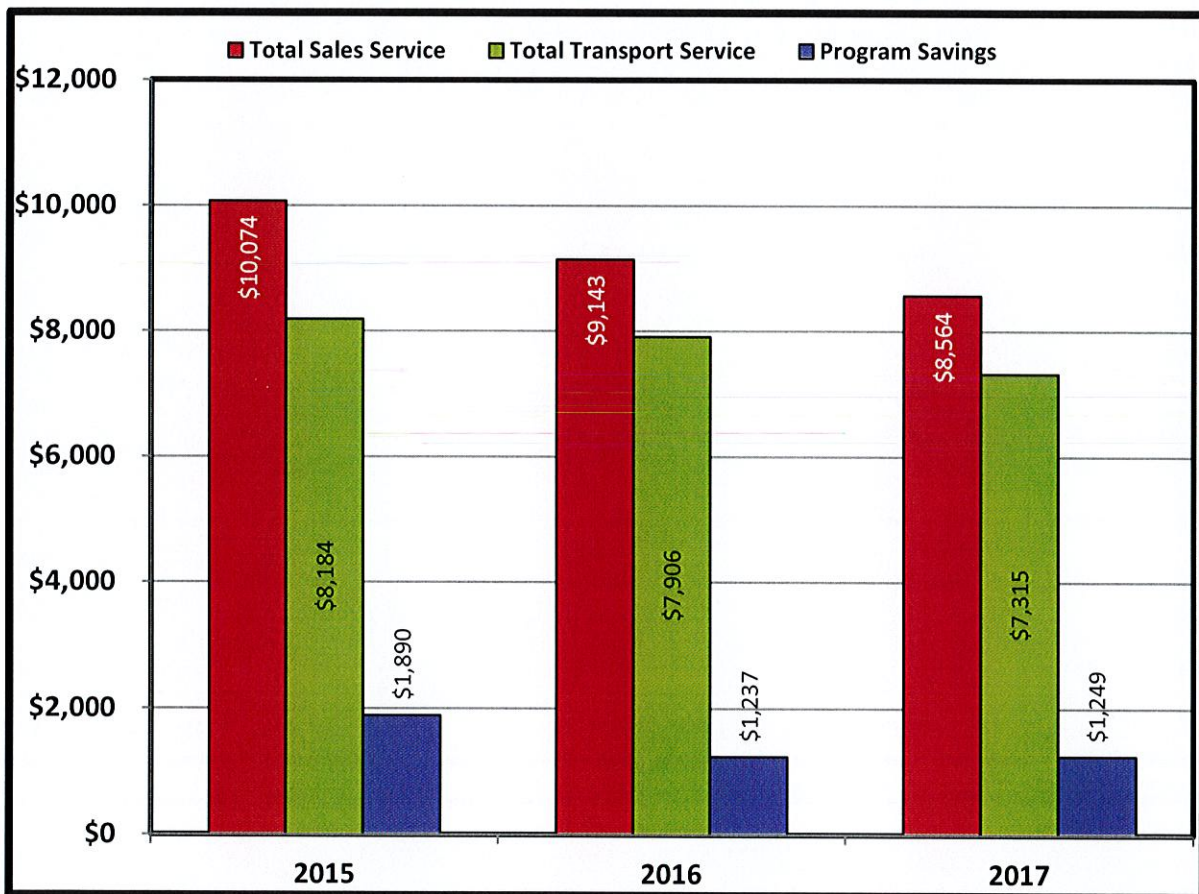

This Master Retail Natural Gas Supply Agreement ("**Master Agreement**") is entered into as of February 9, 2018 ("**Effective Date**") by and between City of Fort Scott, Kansas ("**Customer**") and Constellation NewEnergy – Gas Division, LLC ("**CNEG**"). CNEG and Customer are sometimes referred to individually as a "**Party**" and collectively as the "**Parties**."

This Master Agreement sets forth the general terms and conditions governing transactions for the purchase and sale of natural gas and related products and services (each a "**Transaction**") to one or more of Customer's accounts or facilities (each a "**Facility**") as agreed to from time to time. Each Transaction may be evidenced by a transaction confirmation (each a "**TC**"). The Parties may further agree to implement certain strategies or related services, the specifics of which will be set forth in a rider executed by the Parties (each a "**Rider**"). Each TC and Rider shall constitute part of and shall be subject to this Master Agreement. This Master Agreement and each TC and Rider shall constitute a single integrated agreement between the Parties (collectively referred to as the "**Agreement**"). In the event of a conflict between (i) a TC, (ii) a Rider, (iii) the terms and conditions of this Master Agreement, and (iv) any oral agreement of the Parties as to a Transaction, the terms shall govern in the priority listed in this sentence.

The Parties intend that they are legally bound by the terms of each Transaction from the moment each Party agrees to those terms, whether (i) via electronic transmission, (ii) written record, or (iii) orally. Nothing in this Agreement obligates either Party to enter into a Transaction at any time. Any applicable requirement that a Transaction be "in writing" and "signed" shall be deemed to have been satisfied by this Master Agreement, by the Parties' signatures below and their express agreement to these procedures. CNEG shall have the exclusive right to confirm any Transaction by sending Customer a written TC, substantially in the form attached hereto as Exhibit A or otherwise, by facsimile, e-mail or other means. Notwithstanding any provision to the contrary in this Master Agreement, failure to send a TC shall not invalidate a Transaction agreed to by the Parties. If CNEG sends a TC and Customer fails to object in writing to any term in the TC within two (2) Business Days, the TC shall constitute the definitive written expression of the Transaction. "**Business Day**" means any day except a Saturday, Sunday, or a Federal Reserve Bank holiday and shall open at 8:00 a.m. and close at 5:00 p.m. Eastern Prevailing Time.

1. CNEG and Customer Obligations.

Natural Gas Supply. CNEG shall sell and supply, and Customer shall purchase and receive, the Contract Quantity for each Facility identified in a TC or Rider. "**Contract Quantity**" means the quantity of gas to be delivered and received pursuant to a TC. Such deliveries and receipts of natural gas shall be on a Firm, Secondary Firm or Interruptible basis, or otherwise as described in a TC. "**Firm**" means deliveries and receipts may not be interrupted without liability except for reasons of Force Majeure. "**Secondary Firm**" means deliveries and receipts will be on a best-efforts basis up to Customer's maximum daily quantity and performance may be interrupted without liability to the extent that one or more of the following conditions are present: (i) Force Majeure; (ii) curtailment by the local distribution company owning and/or controlling and maintaining the distribution system required for delivery of gas to the Facility(ies) (the "**Utility**"); (iii) curtailment of supply by a natural gas supplier; (iv) curtailment of storage by a storage provider; (v) curtailment of transportation by a gas gathering or pipeline company, or Utility (each a "**Transporter**"), transporting gas for CNEG or Customer downstream or upstream of the Delivery Point(s), including, but not limited to, transportation between secondary firm points; (vi) recall of transportation capacity release by its releaser; or (vii) curtailment of gas production behind a specific meter. "**Interruptible**" means deliveries and receipts may be interrupted at any time for any reason except for Customer's obligation to take and pay for gas it nominates and CNEG's obligation to honor the price set forth in the TC. The terms of any Transaction between CNEG and Customer shall be as set forth on the applicable TC, but CNEG will procure gas from its suppliers on terms CNEG deems appropriate. CNEG holds title to the gas and has the sole responsibility to deliver, or cause to be delivered, the natural gas to the applicable Delivery Point. Title shall pass to Customer at the Delivery Point and Customer shall have the sole responsibility for transporting the gas from the Delivery Point. "**Delivery Point**" means the city gate interconnection between the Utility and the upstream Transporter or such other delivery point(s) as are agreed in a TC. However, to the extent that Customer owned transportation capacity is used to deliver natural gas to the Customer, the Delivery Point shall be the receipt point of such capacity.

Failure to Deliver or Receive. The sole and exclusive remedy of the Parties in the event of a breach of an obligation to deliver or receive gas shall be the following: (a) If CNEG fails to deliver gas (other than Interruptible) for a reason other than Customer's breach, CNEG shall pay Customer the "**Replacement Cost**," which is the amount Customer actually pays to replace the undelivered Contract Quantity less the amount Customer would have paid under this Agreement for such Contract Quantity. (b) If Customer fails to receive gas (other than Interruptible) for a reason other than CNEG's breach, Customer shall pay CNEG the "**Revenue Loss**," which is the amount that CNEG would have received for the sale of the unreceived Contract Quantity pursuant to this Agreement less (i) the amount actually received by CNEG in an alternate sale, plus any incremental costs, or (ii) if no alternate sale takes place, the amount CNEG would have received by reselling such Contract Quantity at spot market prices at or near the Delivery Point(s), as determined by CNEG in a commercially reasonable manner. CNEG and Customer shall exercise commercially reasonable efforts to mitigate any Revenue Loss or Replacement Cost, respectively. If the calculation of the Replacement Cost or Revenue Loss results in a negative number, then the amount shall be deemed to equal zero.

Nominations. The Parties shall coordinate nomination activities, giving sufficient time to meet the deadlines of the affected Transporter(s). If Customer or the Utility fails to provide CNEG with a usage nomination for any month in a timely manner, CNEG (i) may establish a nomination for such month in a commercially reasonable manner based on Customer's historical usage data available to CNEG, and (ii) shall have the right to use and rely on such nomination unless notified otherwise by Customer or the Utility. If a Party becomes aware that actual deliveries are greater or lesser than the quantity of gas confirmed by a Transporter for movement, transportation or management, the Party shall promptly notify the other Party. Usage nominations may be made orally, in writing, by facsimile or by electronic means.

Imbalances. The Parties shall use commercially reasonable efforts to avoid imposition of any fees, penalties, cash-outs, costs or charges (in cash or in kind) assessed by a Transporter for failure to satisfy balancing and/or nomination requirements ("**Imbalance Charges**"). If either Party receives an invoice from a Transporter that includes Imbalance Charges, the Parties shall determine the validity and cause of such Imbalance Charges. The Party causing the imposition of the Imbalance Charges will be responsible to pay such Imbalance Charges.

Transporter Restrictions. If either Party receives an operational flow order or any other usage or operating instructions, restrictions or similar notice (each an "**OFO**") from a Transporter requiring action to be taken in connection with the flow and/or consumption of gas covered by this Agreement, such party will use commercially reasonable efforts to notify the other party of such event in a timely manner. Such notice may be given by electronic means. Each Party will take all commercially reasonable actions required by the OFO within the time prescribed. If OFO penalties, charges, fees, costs or expenses result from the actions or inactions of one Party, then such Party shall be solely responsible for any such penalties, charges, fees, costs or expenses. Both parties agree that OFOs may require one or both parties to buy or sell gas quantities in the then-current market conditions, which may

be appreciably higher or lower than the original pricing. If CNEG is responsible for nominations and balancing on a Transporter imposing an OFO or similar restriction, CNEG may (but is not required to) increase or decrease nominations, as appropriate, to avoid penalties.

2. Term of Master Agreement. The term of this Master Agreement will commence on the Effective Date and, unless terminated earlier as provided in this Master Agreement, will continue until terminated by either Party upon thirty (30) days prior written notice to the other Party; provided any TC or Rider will continue to be governed by this Master Agreement until the TC or Rider has been separately terminated or expired.

Term of TC. Each TC or Rider shall set forth the applicable "Delivery Period" or term during which deliveries of natural gas are to be made and/or services are to be provided. CNEG shall not be liable for any failure to enroll or drop a Facility by any applicable start and end date(s) set forth in the TC or Rider due to circumstances beyond its control

3. Information and Authorization. Customer hereby authorizes CNEG to take such actions CNEG deems necessary to enroll each Facility with the Utility and to be served by CNEG and to otherwise meet CNEG's obligations under the Agreement, including executing on Customer's behalf any documents necessary to effectuate any Facility enrollment or election, undertaking the management of any storage or transportation capacity allocated to Customer by the Utility or other transporters, disposing of storage balances, adding or deleting Facility(ies) as necessary, receiving usage nominations from the Utility relating to Customer's natural gas requirements, and other similar documents. Customer's signature on this Master Agreement constitutes Customer's written authorization for CNEG to obtain from time to time from the applicable Utility all current and historical natural gas billing, usage data and other related information. Customer shall take any actions, execute any documents and shall provide to CNEG any information as CNEG may reasonably require.

4. Billing and Payment.

Billing. Customer will be billed for natural gas usage and related products and services supplied under the Agreement in one of the following ways based on availability and eligibility of each Facility, which may change from time to time: (a) Dual Billing: Customer will receive two invoices, one from CNEG for the natural gas supply and one from the Utility for the amounts payable by Customer for services provided by the Utility ("Delivery Charges"); (b) CNEG Consolidated Billing: Customer will receive one invoice from CNEG that includes both the natural gas supply charges and the Delivery Charges. In the case of CNEG Consolidated Billing, Customer agrees that (i) Customer remains exclusively liable to the Utility for all Delivery Charges, (ii) CNEG has no obligation to review Delivery Charges for accuracy, (iii) should Customer dispute Delivery Charges, that is a matter for Customer and the Utility to resolve without any involvement or obligation on the part of CNEG, and (iv) CNEG may withhold any payments due to the Utility if Customer fails to pay CNEG invoices in accordance with this Master Agreement.

Taxes. Customer shall pay all federal, state, municipal and local taxes, duties, fees, levies, premiums or other charges imposed by any governmental authority, directly or indirectly, on or with respect to the natural gas and related products and services provided under the Agreement, including without limitation any production, severance or ad valorem taxes, and including any taxes enacted after the Effective Date (collectively, "Taxes"). The term "Taxes" shall include any amounts imposed on Customer directly or on CNEG in its function as Customer's supplier, and that are associated with the supply of gas to Customer (in which case the Customer shall be responsible to reimburse CNEG for such amounts). If Customer is exempt from any Taxes, Customer shall provide CNEG with any state and/or local exemption certificate prior to the issue date of Customer's first invoice. All Taxes invoiced to Customer under this Agreement will be included on the invoice or in the applicable fixed price as allowed by Law.

Estimates. CNEG's ability to invoice Customer is dependent on the Transporter's ability to furnish CNEG with all necessary information, including Customer's metered usage. When there is a delay in receiving information from the Transporter, CNEG will, to the extent necessary, estimate charges and credits for a billing period and reconcile such estimates against actual charges and credits in a future invoice(s). Each invoice is also subject to adjustment for errors in arithmetic, computation, meter readings or other errors. Interest shall not accrue on such adjustments.

Payment. All amounts set forth in an invoice are payable to the Party issuing the invoice and will include, in addition to the natural gas supply charges, Delivery Charges, and Taxes, all other amounts related to the purchase and delivery of natural gas. CNEG's invoices will be sent to Customer in accordance with CNEG's normal billing cycle, as adjusted from time to time. CNEG's invoices are due and payable on the fifteenth (15th) day after the date of invoice or such other date as set forth in a Rider (the "Payment Date") without offset or reduction of any kind, to the address set forth on the invoice. Invoices not paid on or before the Payment Date will accrue interest daily on outstanding amounts from the Payment Date until paid in full, at the lesser of 1.5% per month or the highest rate permitted by law.

Pricing Structures. "Contract Price" means the price for gas as set forth in the applicable TC or Rider. To the extent (a) there are beginning of the month nominated volumes where the price is not fixed, (b) a Facility requires additional natural gas quantities in excess of the nominated or fixed quantities set forth in a TC or Rider, or (c) a Facility continues to receive natural gas from CNEG beyond the Delivery Period (where such deliveries will be considered month to month), all such natural gas will be priced at Market Price unless otherwise set forth in a TC or Rider. "Market Price" means a price comprised of (i) the spot commodity cost of gas as determined by CNEG in its reasonable discretion, (ii) all related interstate and intrastate pipeline charges required to deliver gas to the Delivery Point, and (iii) a reasonable market based margin. Market Price does not include any applicable Utility charges, including but not limited to Utility or pipeline balancing charges, unless otherwise agreed upon.

Market Disruption. If the Contract Price is based in whole or in part upon a specified index and a Market Disruption Event occurs on a day on which the relevant source published or was to publish the relevant price, then the Parties shall negotiate in good faith to agree on an alternative method of determining the Contract Price. A "Market Disruption Event" is any one of the following: (a) failure of the specified index to announce or publish information necessary for determining the Contract Price; (b) the failure of trading to commence or the permanent discontinuation or material suspension of trading in the relevant options contract or commodity on the exchange or market acting as the specified index; (c) the temporary or permanent discontinuance or unavailability of the index; (d) the temporary or permanent closing of any exchange acting as the specified index; or (e) a material change in the formula for or the method of determining the relevant price component.

Price Locks. Unless otherwise set forth in a TC or a Rider, Customer can request to lock in the commodity price for any month(s) at any time during the Delivery Period, prior to 12:00 p.m. EST/EDT on the final day of NYMEX last day settlement for each applicable delivery month. Commodity purchase/sale prices exclude pipeline and Utility distribution charges. Customer also has the right to lock basis at a fixed price and at predetermined volumes. Basis includes interstate and intrastate pipeline transportation but does not include the commodity cost or the Delivery Charges.

5. Adequate Assurance. If CNEG has reasonable grounds: (i) to believe that Customer's creditworthiness has become unsatisfactory; or (ii) for insecurity with respect to Customer's performance under the Agreement, CNEG may demand, in writing, adequate assurance of future performance from Customer in a form, in an amount, from an issuer, and for a term, all as reasonably satisfactory to CNEG ("Adequate Assurance"). To satisfy a demand, Customer shall provide Adequate Assurance to CNEG within three (3) Business Days of the date of the written demand. If at any time CNEG requires Customer to prepay for gas, then (i) CNEG shall be under no obligation to deliver gas if Customer fails to pay any prepayment by its due date,

and (ii) in the event the aggregate cost of any quantities of gas required by Customer in a month in excess of the scheduled nominated quantities exceeds \$15,000.00, Customer shall pay CNEG the aggregate cost of such quantities within three (3) Business Days of CNEG's request for payment.

- 6. Event of Default.** An "Event of Default" means any one of the following: (a) Customer's failure to make, when due, any payment required under the Agreement if not paid within five (5) Business Days (or such longer period required by applicable law) following written notice to Customer that a payment is past due; (b) any representation or warranty made by a Party in the Agreement is false or misleading in any material respect when made or ceases to remain true in all material respects during the term of the Agreement, if not cured within five (5) Business Days after written notice from the other Party; (c) Customer fails to provide the Adequate Assurance as provided in this Agreement; (d) the failure by a Party to perform any material obligation set forth in this Agreement (other than the events that are otherwise specifically covered as a separate Event of Default hereunder or a failure to deliver or receive gas) which is not cured within five (5) Business Days after receipt of written notice thereof; or (e) a Party: (i) makes an assignment or any general arrangement for the benefit of creditors; (ii) has a liquidator, administrator, receiver, trustee, conservator or similar official appointed for it or any substantial portion of its property or assets (iii) files a petition or otherwise commences, authorizes or acquiesces in the commencement of a proceeding or cause of action under any bankruptcy, insolvency, reorganization or similar law for the protection of creditors, or has such petition filed against it; (iv) otherwise becomes bankrupt or insolvent (however evidenced); (v) is unable to pay its debts as they fall due; or (vi) is dissolved (other than pursuant to a consolidation, amalgamation or merger).
- 7. Remedies Upon Event of Default.** If an Event of Default occurs with respect to a Party (the "Defaulting Party"), the other Party (the "Non-Defaulting Party") may, in its discretion, at any time, (i) withhold any payments or suspend any deliveries hereunder and/or (ii) terminate the Agreement in whole or solely with respect to those Facility(ies) adversely affected by such Event of Default, upon written notice to the Defaulting Party setting forth the effective date of termination (the "Early Termination Date"). The Early Termination Date for any Facility located in New Jersey shall be no less than thirty (30) calendar days from the date of written notice of termination. Further, if Customer is the Defaulting Party, then CNEG may, without waiving any rights or remedies it may have, to the extent applicable, remove Customer from CNEG's managed balancing and/or storage pools and/or apply any storage balance at prevailing market prices as an offset against the amount owed to CNEG by Customer. If this Agreement is terminated, the Non-Defaulting Party will in good faith calculate a termination payment as set forth below and the owing Party shall pay such amount within three (3) Business Days of receipt of notice of the amount due. The Parties acknowledge and agree that any termination payment under the Agreement constitutes a reasonable approximation of harm or loss, and is not a penalty or punitive in any respect. The remedies under this Section 7 are the sole and exclusive remedies of the Non-Defaulting Party with respect to the occurrence of any Event of Default.

As of the Early Termination Date, the Non-Defaulting Party shall determine: (i) the difference between the Contract Value and the Market Value, such that the difference shall be due to the Customer if the Market Value exceeds the Contract Value and to CNEG if the opposite is the case; (ii) the Non-Defaulting Party's Costs; and (iii) the amount owed (whether or not then due) by each Party with respect to all gas delivered and received. The Non-Defaulting Party shall net or aggregate, as appropriate, any and all amounts owing between the Parties under this Section, so that all such amounts are netted or aggregated to a single liquidated amount payable by one Party to the other.

"Costs" means, with respect to the Non-Defaulting Party, brokerage fees, commissions and other similar transaction costs and expenses reasonably incurred by such Party as a result of the Event of Default. The "Contract Value" shall be the Contract Price multiplied by the amount of gas, as determined by the Non-Defaulting Party, that would have been delivered under each terminated Rider or TC, had it not been terminated early (the "Terminated Volumes"). The "Market Value" shall be the amount, as of the Early Termination Date, a third party would pay for the Terminated Volumes at the Delivery Point(s) at current market prices. The Non-Defaulting Party may determine the Market Value of a terminated transaction by reference to information either available to it internally or supplied by one or more third parties including, without limitation, any or all of the settlement prices of NYMEX gas futures contracts, quotations from leading dealers, energy swap agreements or physical gas trading markets, similar sales or purchases, and any other bona fide offers from either third parties or affiliates of the Party, all as commercially available to the Party and adjusted for the length of the term and differences in transportation costs and other factors, as the Party reasonably determines. The Non-Defaulting Party shall not be required to enter into a replacement transaction in order to determine or be entitled to a termination payment.

- 8. Change in Law.** CNEG may pass through or allocate, as the case may be, to Customer any increase or decrease in CNEG's costs related to the natural gas and related products and services sold to Customer that results from the implementation of new, or changes (including changes to transportation rates) to existing, Laws, or other requirements or changes in administration or interpretation of Laws or other requirements. "Law" means any law, rule, regulation, ordinance, statute, judicial decision, administrative order, Transporter business practices or protocol, Transporter tariff, or rule of any commission or agency with jurisdiction in the state in which the Facility(ies) is located. Such adjusted amounts will be included in subsequent invoices to Customer.
- 9. Representations and Warranties.** Each Party warrants and represents to the other (now and deemed repeated by each Party on each date on which a TC or Rider is executed or deemed accepted) that: (i) it is duly organized, validly operating and in good standing under the laws of the jurisdiction of its formation; (ii) it is authorized and qualified to do business in the jurisdictions necessary to perform under the Agreement; (iii) execution, delivery and performance of the Agreement are duly authorized and do not violate any governing documents or any of its contracts or any applicable Law; (iv) there is no material event(s) or agreement(s) which would impair that Party's right, authority or ability to execute the Agreement and otherwise perform under the Agreement; and (v) it has the knowledge and experience to evaluate the merits and risks associated with the Agreement.

Furthermore, Customer warrants, represents and covenants that: (i) the data given and representations made concerning its Facility(ies) are true and correct; (ii) it is entering into this Agreement to purchase its natural gas requirements only and not for speculative or resale purposes; and that the natural gas purchased under this Agreement will be consumed at the Facility(ies); (iii) it is the party of record of the Facility(ies), or if it is not the party of record, it has the authority to enter into and bind its principal to the Agreement; (iv) if any Transaction hereunder gives Customer the right to adjust the Contract Quantity, or to require CNEG to provide some other quantity of gas, Customer's election to exercise such right is based predominantly on supply and demand factors related to Customer's business; and (v) if Customer is a Governmental Entity, it will not claim immunity on grounds of sovereignty or similar grounds from enforcement of the Agreement. If it is a Governmental Entity, Customer covenants to obtain all necessary budgetary approvals, appropriations and funding for all of its obligations under this Agreement, the failure of which shall not be an excuse for Governmental Entity's performance or failure to perform hereunder and upon request will provide proof of such authority. "Governmental Entity" means a municipality, county, governmental board, governmental department, commission, agency, bureau, administrative body, joint action agency, court or other similar political subdivision (including public school districts or special purpose district or authority), or public entity or instrumentality of the United States or one state.

- 10. Force Majeure.** Notwithstanding any other provision of this Agreement, where a Party is unable to carry out any obligation under the Agreement due to a Force Majeure event (other than a payment obligation, which will not be excused for Force Majeure), the Agreement will remain in effect but such obligation will be suspended for the period necessary as a result of the Force Majeure, provided that: (i) the Claiming Party gives the other Party, as soon as possible, written notice describing the particulars of the Force Majeure; (ii) the suspension of performance is of no greater scope and of no longer duration than is required by the Force Majeure; and (iii) the Claiming Party uses commercially reasonable efforts to remedy its inability to perform.

"Force Majeure" means an event that is not within the reasonable control of the Party claiming Force Majeure ("Claiming Party"), and that by the exercise of due diligence, the Claiming Party is unable to overcome the event in a commercially reasonable manner, and such event will not be deemed a breach or default under the Agreement. Force Majeure includes, but is not limited to, acts of God; fire; war; terrorism; flood; earthquake; civil disturbance; sabotage; facility failure; strike; curtailment, disruption or interruption of supply by a supplier or distribution or transportation by a Transporter (including without limitation as the result of an OFO); declaration of emergency by a Transporter(s); regulatory, administrative, or legislative action, or action or restraint by court order or governmental authority; or any act or omission of a third party not under the control of the Claiming Party (including without limitation the Utility).

11. **Indemnification.** Before title passes to Customer at the Delivery Point CNEG shall, and after title passes at the Delivery Point Customer shall, defend, indemnify and hold harmless the other Party and all its affiliates, and all of their respective officers, directors, shareholders, associates, employees, agents, representatives, successors and assigns, from and against all claims, losses, expenses (including reasonable attorneys' fees and court costs), damages, demands, judgments, causes of action or suits of any kind, including but not limited to, claims for personal injury, death, or property damage, to the extent arising out of or related to this Agreement ("Claims").
12. **Limitation of liability.** NOTWITHSTANDING ANY OTHER PROVISION OF THE AGREEMENT TO THE CONTRARY, THE ENTIRE LIABILITY OF EACH PARTY FOR ANY AND ALL CLAIMS WILL BE LIMITED TO DIRECT ACTUAL DAMAGES ONLY, SUBJECT IN ALL CASES TO AN AFFIRMATIVE OBLIGATION ON THE PART OF EACH PARTY TO MITIGATE ITS DAMAGES, AND NEITHER PARTY WILL BE LIABLE FOR ANY CONSEQUENTIAL, EXEMPLARY, SPECIAL, INCIDENTAL OR PUNITIVE DAMAGES, INCLUDING, WITHOUT LIMITATION, LOST OPPORTUNITIES OR LOST PROFITS NOT CONTEMPLATED BY THE TERMINATION CALCULATION IN SECTION 7 ABOVE. Customer acknowledges and agrees that the Utility is exclusively responsible for the gas distribution and delivery system, that CNEG has no independent control over the Utility's systems and will have no liability for any of the Utility's acts or omissions.
13. **DISCLAIMER.** CUSTOMER ACKNOWLEDGES AND AGREES THAT NO WARRANTY, DUTY, OR REMEDY, WHETHER EXPRESSED, IMPLIED, OR STATUTORY, IS GIVEN OR INTENDED TO ARISE OUT OF THIS AGREEMENT EXCEPT AS OTHERWISE EXPRESSLY STATED HEREIN, AND CNEG SPECIFICALLY DISCLAIMS ALL OTHER WARRANTIES, EXPRESSED OR IMPLIED, INCLUDING ANY WARRANTY OF MERCHANTABILITY OR FITNESS FOR A PARTICULAR PURPOSE OR USE.
14. **Waiver and Severability.** Failure to provide notice of, or object to, any default under this Agreement will not operate or be construed as a waiver of any future default, whether like or different in character. If any portion of this Agreement, or application thereof to any person or circumstance, is held legally invalid, the remainder will not be affected and will be valid and enforced to the fullest extent permitted by law and equity, and there will be deemed substituted for the invalid provisions such provisions as will most nearly carry out the mutual intent of the Parties as expressed in this Agreement to the fullest extent permitted by applicable Law; provided, however, that this severability provision will not be applicable if any provision of Sections 6 and 7 of this Master Agreement (or any definition or provision in this Agreement to the extent it relates to, or is used in connection with, such sections) is held invalid or unenforceable.
15. **Assignment.** Customer may assign all its rights and obligations under this Agreement; *provided* (a) it gives CNEG forty-five (45) days prior written notice of its intent to do so; (b) the assignee satisfies in full CNEG's credit requirements; (c) the assignee assumes in writing all of Customer's obligations under the Agreement; and (d) Customer continues to be liable for performance, including payment for goods and services received, prior to the assignment date. CNEG may assign, sell, pledge, transfer, or encumber any of its rights and obligations under this Agreement or the accounts, revenues, or proceeds hereof to: (a) a bank, insurer or other financial institution; or (b) any person or entity (i) succeeding to all or substantially all of CNEG's assets or business or the division or region of CNEG to which this Agreement relates or (ii) into which CNEG is merged or otherwise combined or reorganized; provided (with respect to this clause (b)) the succeeding entity agrees to be bound to the Agreement; or (c) any affiliate of CNEG.
16. **Confidentiality.** Each Party agrees to keep all terms and provisions of this Agreement and all communication provided in connection with this Agreement, including the pricing offered to Customer, confidential to the extent not otherwise publicly available and not to disclose them to any third parties without the prior written consent of the other Party, except as necessary to perform its obligations under this Agreement or as otherwise required by Law. Each Party may disclose such information to its affiliates and to its affiliates' employees, agents, advisors, and on a need to know basis, to its independent contractors, provided each such recipient agrees to hold such information in the strictest confidence. CNEG may disclose information respecting Customer to third parties that are representing Customer in the purchase of gas or related services. Furthermore, CNEG may make such other disclosures to third parties of information, including aggregate consumption data, provided they are in a manner that cannot be reasonably expected to specifically identify Customer. If disclosure of confidential information is sought through a court, or a state or federal regulatory agency or other legal compulsion, the Party receiving such request will notify the other Party immediately to afford it the opportunity to oppose such disclosure via a protective order or other relief as may be available and will provide reasonable support.
17. **Choice of Law, Venue, Attorney Fees and Expenses.** This Agreement will be governed and interpreted in accordance with the laws of the State of New York, without giving effect to conflict of law principles. TO THE EXTENT ALLOWED BY APPLICABLE LAW, EACH PARTY HEREBY IRREVOCABLY AND UNCONDITIONALLY WAIVES ANY RIGHT SUCH PARTY MAY HAVE TO A TRIAL BY JURY OR TO INITIATE OR BECOME A PARTY TO ANY CLASS ACTION CLAIMS IN RESPECT OF ANY ACTION, SUIT OR PROCEEDING DIRECTLY OR INDIRECTLY ARISING OUT OF OR RELATING TO THIS AGREEMENT OR THE TRANSACTIONS CONTEMPLATED BY THIS AGREEMENT. If either Party pursues court action to enforce its rights under this Agreement, the non-prevailing Party shall promptly reimburse the prevailing Party for all its reasonable attorney fees, expenses and costs.
18. **Miscellaneous.** The Agreement embodies the Parties' entire agreement and understanding and may not be contradicted by any prior or contemporaneous oral or written agreement. Notwithstanding any provision to the contrary in a prior agreement, the Parties agree that this Master Agreement shall supersede and replace all prior written and oral agreements or arrangements between the Parties with respect to the purchase and sale of gas and related services and that all transactions under any such prior agreement(s) are, as of the Effective Date, now governed solely by the terms of this Master Agreement and shall be Transactions hereunder and a part of the single integrated agreement between the Parties. A facsimile or e-mailed copy of either Party's signature will be considered an original for all purposes under this Agreement, and each Party will provide its original signature upon request. No purchase order, or any amendment or edit to this Agreement, will be valid or given any effect unless signed by both Parties or expressly contained in a TC deemed accepted pursuant to the procedures set forth herein. The applicable provisions of this Agreement will continue in effect after termination or expiration hereof to the extent necessary, including but not limited to providing for final billing, billing adjustments and payments, limitations of liability, the forum and manner of dispute resolution, and with respect to any indemnification obligations under the Agreement. The section headings used in this Master Agreement are for reference purposes only and will in no way affect the meaning of the provisions of the Master Agreement. The Parties acknowledge that any document generated by the Parties with respect to this Agreement, including this Agreement, may be imaged and stored electronically and such imaged documents may be introduced as evidence in any proceeding as if such were original business records and neither Party shall contest their admissibility as evidence in any proceeding. The rights, powers, remedies and privileges provided in this

Agreement are cumulative and not exclusive of any rights, powers, remedies and privileges provided by Law. CNEG shall have the right to set-off and net against any amounts owed to it under the Agreement, including without limitation any early termination payment, any amounts owed by CNEG to Customer under the Agreement or any other agreement between the Parties, including without limitation any Adequate Assurance. Except for Section 11 above, no third party will have any rights under this Agreement whatsoever and Customer will be fully responsible for any compensation owing any third party representing Customer in connection with this Agreement and will indemnify, defend and hold harmless CNEG from all related Claims. To the extent Customer is represented by a broker, agent, association or other third party (collectively, "Broker"), Customer acknowledges and understands that: (i) CNEG may be making a payment to Broker in connection with Broker's efforts to facilitate Customer and CNEG entering into a Transaction; (ii) unless otherwise noted, the Contract Price reflects the fee, if any, paid to Broker, and (iii) Broker is acting on Customer's behalf as Customer's representative and is not a representative or agent of CNEG. Customer further authorizes CNEG to utilize Customer's name for publicity and marketing purposes.

- 19. Affirmation; Acknowledgements.** Customer affirms that it has read this Agreement in its entirety and it agrees to the terms and conditions contained herein. Any ambiguity or question of intent or interpretation under this Agreement will be construed as if drafted jointly by the Parties, and no presumption or burden of proof will arise favoring or disfavoring either Party by virtue of the authorship of any of the provisions of this Agreement. The Parties acknowledge and agree that: (i) CNEG is an independent contractor under this Agreement and except as otherwise explicitly provided in this Agreement, neither Party has the authority to execute documents that purport to bind the other, and nothing in this Agreement will be construed to constitute a joint venture, fiduciary relationship, partnership or other joint undertaking; (ii) TCs and Riders entered into hereunder will constitute "forward contracts" and/or "swap agreements" under the U.S. Bankruptcy Code, as amended, the rights of the Parties under Section 7 above will constitute contractual rights to liquidate them, and the Parties are entities entitled to the rights and protections afforded to "forward contracts" and "swap agreements" by the U.S. Bankruptcy Code; (iii) CNEG is not Customer's consultant or advisor for any purpose including advice regarding the value or advisability of trading in "commodity interests" as defined in the Commodity Exchange Act, 7 U.S.C. §§ 1-25, et seq., as amended (the "CEA"), including futures contracts and commodity options or any other activity which would cause CNEG or any of its affiliates to be considered a commodity trading advisor under the CEA; (iv) each Party is an "eligible contract participant" as that term is defined in the CEA; and (v) Customer is making its own decisions based solely upon its own analysis and the advice of its own advisors, if any.
- 20. Notices.** To be effective, all notices must be in writing delivered by hand, by certified mail return receipt requested, by first class mail, or express carrier to the addresses provided in this Agreement. CNEG shall send invoices and TCs to the notice address provided herein unless otherwise directed by Customer. Notice by hand delivery shall be effective on the date it is delivered. Notice by certified mail, return receipt requested, by first class mail, or express carrier shall be effective on the date that mail is delivered or its delivery is attempted. A Party may change its address by providing notice of change in accordance herewith or by other means agreed by the Parties.

CNEG Notice Information

9960 Corporate Campus Drive, Suite 2000
Louisville, KY 40223
Attention: Contracts Administration
Phone: (502) 426-4500
Facsimile: (502) 214-6381

Customer Notice Information

Legal Notice Information
Attention: Jon Garrison
Title: Director of Finance
Address: 123 S MAIN ST, FORT SCOTT, KS 66701
Phone: (620) 223-0550
Facsimile:
Email: jgarrison@fscity.org

For Invoices (if different from Notice Information)

Attention:
Title:
Address:
Phone:
Facsimile:
Email:

For Transaction Confirmations (if different from Notice Information)

Attention:
Title:
Address:
Phone:
Facsimile:
Email:

{SIGNATURES FOLLOW ON NEXT PAGE}

IN WITNESS WHEREOF, THE PARTIES HAVE EXECUTED THIS DOCUMENT THROUGH THEIR DULY AUTHORIZED REPRESENTATIVES.

CNEG

Sign and Print Name: _____

Print Title: _____

CUSTOMER

Sign and Print Name: _____

Print Title: _____

EXHIBIT A – FORM OF TRANSACTION CONFIRMATION*

**The actual Transaction Confirmation entered into between Customer and CNEG may differ from this form to reflect state regulatory and other local requirements and terms applicable to the Facility. This Form of Transaction Confirmation is for illustrative purposes only and CNEG reserves the right to alter the form of this Transaction Confirmation at any time.*

This Transaction Confirmation is delivered pursuant to and in accordance with a Master Retail Natural Gas Supply Agreement effective _____, 20__ (the "Master Agreement"), by and between Constellation NewEnergy – Gas Division, LLC ("CNEG") and _____ ("Customer"), and is subject to and made part of the terms and conditions of such Master Agreement. Capitalized terms used herein but not defined will have the meanings ascribed to them in the Master Agreement.

Trade Date:

Buyer:

Seller:

Facility Name:

Delivery Period:

Nature of Parties' Obligation:

Deal Type:

Contract Quantity/Price:

Month/Yr	Contract Quantity (in MMBtu)	Contract Price

Incremental Pricing:

Delivery Point(s):

Utility:

Default Service: To the extent a Facility continues to receive gas from CNEG beyond the Delivery Period, all such gas will be considered month to month purchases and will be priced at the Market Price.

Special Provisions:

This Transaction Confirmation documents an agreement previously reached by authorized representatives of the Parties. Unless disputed by Customer in writing within two (2) business days of Constellation's execution date, or such time frame as specified in the Master Agreement, it is binding and shall be deemed accepted.

CONSTELLATION NEWENERGY – GAS DIVISION, LLC

CUSTOMER

By: _____
Name: _____
Title: _____
Date: _____

By: SAMPLE _____
Name: NOT FOR EXECUTION _____
Title: _____
Date: _____

SMARTPORTFOLIO PROGRAM (FULL REQUIREMENTS)

This SmartPortfolio Rider (“Rider”) is made part of and is subject to the natural gas agreement entered into on February 9, 2018 (the “**Master Natural Gas Agreement**”), by and between Constellation NewEnergy – Gas Division, LLC (“CNEG”) and City of Fort Scott, Kansas (“Customer”). The Master Natural Gas Agreement and this Rider together are referred to as and constitute the “**Master Agreement**” between the Parties. The purpose of this Rider is to set forth the specific terms and conditions related to the SmartPortfolio Program whereby CNEG will supply natural gas to Customer’s facilities (“Facilities”) listed below in the Facility Listing. Capitalized terms used herein but not defined will have the meanings ascribed to them in the Master Natural Gas Agreement. In the event of a conflict between this Rider and the Master Natural Gas Agreement, the terms of this Rider shall govern with respect to the services described herein.

1. SmartPortfolio Overview. The SmartPortfolio Program (“SmartPortfolio” or “SmartPortfolio Program”) is a complete approach for managing physical natural gas purchases and protecting against price volatility. SmartPortfolio manages spot market gas deliveries and, over time, locks in a fixed price for the elected volumes. The intent of SmartPortfolio is to provide a time diversified physical gas price which utilizes a time-proven, systematic, and algorithmic approach to risk management. The “SmartPortfolio Price” includes the commodity price, basis, transportation, fuel, and CNEG’s costs to deliver gas and provide SmartPortfolio Services as described herein. The SmartPortfolio Price does not include any applicable taxes or utility distribution charges.

2. SmartPortfolio Services. As part of SmartPortfolio, CNEG will designate an Account Manager to provide the SmartPortfolio Services as described herein. The Account Manager will serve as the Customer’s point of contact and manage the relationship between CNEG and the Customer. Customer will be provided a username and password to access CNEG’s secured web-based portal. Customer will be able to view online reports identifying volumes for which prices have been fixed through the SmartPortfolio Program over time as well as cumulative purchases since the inception of Customer’s participation in the SmartPortfolio Program. Account specific information and reports can be viewed and printed. Examples of account specific reports that may be available include: (a) monthly analysis reports, (b) daily usage histories, and (c) monthly usage and peak day analysis. Market based information can also be viewed and printed from the portal. Examples of market based information may include: (a) Weekly Market Summary, (b) Natural Gas Market Update, (c) Natural Gas Futures Update, and (d) historical NYMEX pricing. Annual energy conferences and periodic webinars will be provided covering the latest information on the energy markets, regulatory and legislative changes, and product and service developments.

3. Volumetric Participation. CNEG shall be the exclusive natural gas supplier to the identified Facilities during the term of this Rider. The SmartPortfolio Price will apply to all volumes delivered to Customer by CNEG. Forecasted monthly volumes (“Monthly Volumes”) are listed below for each Facility in the Facility Listing.

4. Purchasing Strategy. SmartPortfolio manages both commodity and basis, which are two main components of physical gas pricing. Each component will be managed in accordance with the following purchasing strategies:

- a. **Commodity.** SmartPortfolio leverages time to diversify physical gas commodity price risk and will fix a commodity price for volumes up to the amount of the Volatility Protection Percentage selected below based on the number of months remaining in the term and Customer’s Monthly Volumes (“SmartPortfolio Commodity Price Risk Management Purchasing Strategy”). For example, if at the beginning of the Initial Term there are twenty (20) months remaining before a specific delivery month, approximately 1/20 (5.0%) of Customer’s Monthly Volumes in Volatility Protection for that delivery month will be fixed each month prior to the delivery month.

Customer’s SmartPortfolio “Volatility Protection Percentage” is indicated below. The Volatility Protection Percentage is the percentage of commodity volumes purchased pursuant to the SmartPortfolio Commodity Price Risk Management Purchasing Strategy. The higher the percentage, the greater the volatility protection. For example, if Customer chooses 75% Volatility Protection, 75% of the Monthly Volumes will have the price fixed in advance of the month of flow pursuant to the SmartPortfolio Commodity Price Risk Management Purchasing Strategy and the remaining 25% will be priced at then-current market prices during the month of delivery.

0%	25%	50%	75%	Custom %
X				

- b. **Basis.** SmartPortfolio leverages time diversification principles for physical basis requirements by purchasing for forward flow periods using a modified dollar cost averaging methodology whereby SmartPortfolio purchases forward basis during summer months (April through October) but purchases forward basis for all forward flow months (January through December) for a two (2) year forward window. SmartPortfolio does not purchase forward physical gas basis during winter (November through March). SmartPortfolio further diversifies physical gas basis requirements by locking approximately 50% of Customer’s Monthly Volumes and floating 50% to be priced at then-current market price (“SmartPortfolio Basis Price Risk Management Purchasing Strategy”); provided, however, CNEG may modify this methodology as needed due to market liquidity constraints. If applicable, Customer will select a reliability level for its purchases from CNEG and CNEG will aggregate Customer’s volumes with other customers CNEG is physically serving (“Reliability Pool”).

5. Term of Obligation. The initial term of this Rider will commence on March 1, 2018 (“Term Start Date”) and shall be for a period of twenty-four (24) months (“Initial Term”). Customer acknowledges that any termination of the Master Natural Gas Agreement shall not be effective while this Rider is in effect, unless due to an Event of Default. Following the Initial Term, this Rider will automatically renew for additional twelve (12) month periods (each a “Renewal Term”) with the same program elections (e.g., Volumetric Participation and Volatility Protection) unless either party provides the other with written notice of its intent to terminate twelve (12) months prior to the end of the Initial Term or any Renewal Term. For each Renewal Term, CNEG may change the Monthly Volumes based on Customer’s actual usage.

6. Guarantee Period and Rider Modification. Customer may request modification of the Volatility Protection or Initial Term and/or withdrawal from SmartPortfolio within thirty (30) days following Customer’s signature date below (the “Guarantee Period”) without an early termination payment. However, any actual amendments to this Rider will be made in accordance with the Master Natural Gas Agreement and will require mutual agreement and signature of both Parties. CNEG will process the written request and will notify Customer of its acceptance or rejection of Customer’s request within seven (7) calendar days from CNEG’s receipt of the request. Any Rider modification requests after the Guarantee Period including, but not limited to, changes to Volatility Protection, or Initial Term and/or withdrawal from SmartPortfolio may result in an early termination payment with regard to any volumes for which prices have been fixed through the SmartPortfolio Program. Customer acknowledges that, even if Customer terminates during the Guarantee Period when no early termination payment will apply, Customer will remain responsible for payment for any natural gas delivered to Customer prior to termination.

7. Level of Service and Delivery Point. All gas delivered pursuant to this Rider shall be Firm and shall be delivered to the applicable Facility's Utility citygate. However, to the extent that Customer owned transportation capacity is used to deliver natural gas to the Customer, the Delivery Point shall be the receipt point of such capacity.

8. Acknowledgment of SmartPortfolio Purchasing Strategy. Customer acknowledges and agrees to the SmartPortfolio purchasing strategies and processes set forth in this Rider. No guarantees are made or implied that a specific price will be achieved. The Purchasing Strategy is subject to modification by CNEG at any time, for any reason ("**New Purchasing Strategy**"). Should CNEG issue a New Purchasing Strategy, CNEG shall send Customer written notice and details of the New Purchasing Strategy and Customer will have the option of declining to participate in the New Purchasing Strategy, but may only exercise such option by providing timely written notice of its non-participation to CNEG. If Customer's notice of non-participation in the New Purchasing Strategy is not received by CNEG within twenty (20) calendar days of the date of the New Purchasing Strategy notice, then Customer shall be deemed to have accepted such New Purchasing Strategy and will be subject to the methodologies contained therein.

9. Transporter Restrictions. Both parties agree that operational flow orders or other usage or operating instructions (each an "OFO") from a pipeline or utility may require one or both parties to buy or sell gas quantities in the then-current market conditions, which may be appreciably higher or lower than what the SmartPortfolio price would have been absent the OFO. During OFOs, CNEG may (but is not required to) increase or decrease nominations, as appropriate, to avoid penalties.

This SmartPortfolio Rider shall not be binding or enforceable against CNEG unless and until signed by an authorized representative of CNEG.
This Rider may be executed by in multiple counterparts, each of which shall be deemed an original and all of which together shall constitute one and the same instrument.

(SIGNATURES FOLLOW FACILITY LISTING)

FACILITY LISTING

Annual Volume - 2,290 Dth

Facility Location(s)							Utility	Utility Account Number		Meter Number	CNEG Customer ID	
2101 Sidney Street, FORT SCOTT, KS							KGS	510129508 1186260		0316B02549	RG-241009	
Jan.	Feb.	March	April	May	June	July	Aug.	Sep.	Oct.	Nov.	Dec.	Facility Total
329	242	161	69	27	6	5	4	4	7	40	167	1,061
Facility Location(s)							Utility	Utility Account Number		Meter Number	CNEG Customer ID	
1 East 3rd Street, FORT SCOTT, KS							KGS	510717550 1185317		0302600242	RG-241010	
Jan.	Feb.	March	April	May	June	July	Aug.	Sep.	Oct.	Nov.	Dec.	Facility Total
408	308	154	87	33	9	0	0	0	0	38	192	1,229

IN WITNESS WHEREOF, THE PARTIES HAVE EXECUTED THIS DOCUMENT THROUGH THEIR DULY AUTHORIZED REPRESENTATIVES.

CNEG

Sign and Print Name: _____

Print Title: _____

CUSTOMER

Sign and Print Name: _____

Print Title: _____